

# Airsum®

CAJAS DE VENTILACION "TBS"(Transmission Box Single)

*Caisson de Ventilation "TBS"*

VENTILATION MOTOR BOX "TBS"

*Unidades de Ventilação "TBS"*



CE

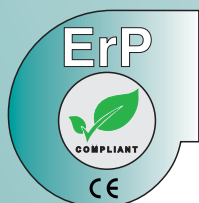
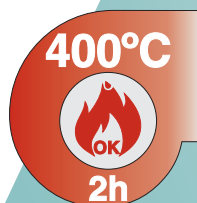

CAJAS DE VENTILACION

"TBS-S" y "TBS-F"

(Con Ventiladores  
de  
Simple Aspiración)

TBS-F- Ventilador homologado según norma UNE EN-12101-3:2002 con certificación CE.



difusión

acústica

cortafuegos



**GENERALIDADES**

La familia de cajas de ventilación "TBS" (Transmission Box Single), está compuesta por dos series:

- Cajas de ventilación a transmisión "TBS-F" 400°C/2h, previstas para un doble uso, extracción de aire convencional y de emergencia con aire a 400°C durante 2h, para trabajar en el exterior de la zona de riesgo, con ventilador centrífugo de simple aspiración tipo acción, homologado según norma **UNE EN-12101-3:2002** y con certificación **CE**.

- Cajas de ventilación a transmisión "TBS-S", con ventilador centrífugo de simple aspiración tipo acción. Previstas para impulsión o extracción de aire.

Ambas están fabricadas en chapa de acero galvanizado **Z-275** y recubiertas interiormente con aislamiento termoacústico de gran eficacia y comportamiento al fuego **B s1 d0** según **UNE-EN 13501-1** o similar, que reduce sensiblemente el ruido. Disponen de tapa de registro para acceder al ventilador y motor.

Contienen en su interior un ventilador centrífugo de simple aspiración con rodete de álabes insertos, equilibrado estática y dinámicamente con máquinas electrónicas de alta sensibilidad según norma **VDI-2060** y grado de equilibrado **Q=6.3**. El ventilador está accionado mediante transmisión por poleas y correas con un motor montaje B3 situado en el interior de la caja.

El grupo moto-ventilador queda aislado de la caja al estar montado sobre soportes antivibratorios y junta flexible en aspiración y descarga. En el caso de la serie "TBS-F" la junta flexible es homologada 400°C/2h. Con este sistema no es necesario prever amortiguadores ni conexiones flexibles en el exterior de las cajas.

El motor queda incorporado dentro de la caja, fuera de la corriente de aire y sobre un soporte motor deslizante para facilitar de manera sencilla y precisa el sistema de tensionado y alineación de la transmisión. Las cajas van provistas de un prensaestopas al exterior para facilitar la salida de los cables de conexionado.

Las temperaturas límites de funcionamiento en continuo para la serie "TBS-S" son de **-20°C a +80°C** para los tamaños hasta el 18/9 y **-20°C a +110°C** para los tamaños a partir del 20/10, y para la serie "TBS-F" son de **-40°C a +150°C** para todas ellas.

La fabricación estándar es con descarga Horizontal (**RD-90/OR1**) y con el motor a la izquierda visto desde la boca de impulsión. Bajo demanda se pueden montar con el motor situado a la derecha visto desde la boca de impulsión y con descarga Vertical, con el motor situado tanto a la izquierda como a la derecha (**LG-90/OR9, RD-0/OR7, LG-0/OR15** ver página 14).

**MOTORES**

Según la directiva 2005/32/CE. "A partir del 1 de enero de 2017: los motores con una potencia nominal de 0,75-375 kW no podrán tener un nivel de rendimiento inferior al nivel de rendimiento IE3, definido en el anexo I, punto 1, o al nivel IE2, definido en el anexo I, punto 1, y estar equipados de un mando de regulación de velocidad".

Los motores son trifásicos de eficiencia **IE2/IE3** según norma Europea **IEC**, protección **IP-55**, con aislamiento clase F, montaje B3, cojinetes con rodamientos a bolas y protector térmico incorporado. Para tensión de 230/400 V – 50 Hz (hasta 4,0 kW) y 400/690 V – 50 Hz (para potencias mayores de 4,0 kW).

**MONTAJE**

Cada unidad va provista de soporte de anclaje para su montaje indistintamente tanto apoyada como colgada.

**APLICACIONES**

Las dos series de cajas "TBS" son apropiadas para la renovación de aire convencional como impulsoras o extractoras en cualquier tipo de locales.

Las cajas "TBS-F" 400°C/2h, con ventilador homologado según norma **UNE EN-12101-3:2002** y con certificación **CE**, pueden ser además utilizadas para:

- La evacuación de humos (desenfumage) en caso de incendios, por ejemplo en garajes, centros comerciales, etc.
- Los sistemas de extracción de humos de las cocinas consideradas de riesgo especial (potencia instalada mayor a 20 kW) por el **CTE** en su **DB S11**. Especialmente indicadas para este tipo de instalaciones (cocinas industriales, barbacoas, asadores, etc.), al no trasegar por ellas los humos a alta temperatura (solo a través del ventilador).

**GAMA**

Disponibles en 9 modelos con potencias de motor comprendidas entre 0,25 kW hasta 15,0 kW.

Cubren un margen de caudal desde 1100 m<sup>3</sup>/h hasta 26.700 m<sup>3</sup>/h, con presiones estáticas máximas de entre 1000 y 1200 Pa según tamaños

**ACCESORIOS OPCIONALES** (Bajo demanda)

- Techo para intemperie (en descarga horizontal).
- Visera de impulsión con malla anti-pájaros.
- Motores de 2 velocidades.
- Regulador de velocidad trifásico (convertidor) para regulación por frecuencia.
- Interruptor de seguridad paro-marcha.



## RECOMENDACIONES

Atendiendo al criterio de nivel sonoro, según la aplicación de la caja, se recomienda seleccionar las cajas con las siguientes velocidades de impulsión:

- **Silenciosa:** velocidad de salida del aire de 9 a 10m/s (valor **C** de la curva) (instalaciones de ventilación donde el nivel sonoro deba ser mínimo, por ejemplo, viviendas, salas de conferencias, cines, hospitales, etc.).
- **Estándar:** velocidad de salida del aire de 10 a 14 m/s (valor **C** de la curva) (instalaciones de ventilación normal sin ningún requerimiento especial, por ejemplo, oficinas, centros comerciales, restaurantes, etc.).
- **Industrial:** velocidad de salida del aire de 14 a 16 m/s (valor **C** de la curva) (instalaciones de ventilación donde el nivel sonoro no necesita ser especialmente bajo o es superior al que generan las propias cajas, por ejemplo, aparcamientos, cocinas industriales, etc.).

La selección de una caja de ventilación consiste en determinar el tamaño de caja adecuado, potencia del motor y revoluciones del ventilador para las condiciones de caudal y presión requeridas, teniendo en cuenta las siguientes consideraciones:

- **Criterios económicos,** intentar seleccionar la caja con el mayor rendimiento posible ya que a mayor rendimiento seleccionado menor consumo eléctrico y menor coste económico a largo plazo.
- **Espacio disponible,** se adjunta croquis en cada curva con las dimensiones generales de la caja.
- **Nivel sonoro** en el caso de que sea un criterio a tener en cuenta debido a la aplicación en la que es utilizada la caja (Silencioso, Estándar, Industrial).

## EJEMPLO DE SELECCIÓN CAJAS DE VENTILACIÓN "TBS" (Transmission Box Single)

Las condiciones de trabajo deseadas son:

- Caudal de 5.500 m<sup>3</sup>/h.
- Pérdida de carga estática a vencer de la red de conductos de 600 Pa.

Para las condiciones dadas, podríamos seleccionar dos cajas (ver gráfica página 4):

TBS-18/9 con motor de 2,2 kW – mayor rendimiento (62%), menor consumo eléctrico, mayor tamaño y mayor coste.  
TBS-15/7 con motor de 3,0 kW – menor rendimiento (56%), mayor consumo eléctrico, menor tamaño y menor coste.  
Dependiendo de la instalación, aplicación de la caja e importe de la misma, se decidiría cual de las dos variantes es la más apropiada.

## TABLAS DE CONVERSION

PRESION							
	Pa	mbar	bar	kg/cm <sup>2</sup>	mm.c.d.a.	mm Hg	psi
1 Pa	1	0,01	1x10 <sup>-5</sup>	102x10 <sup>-7</sup>	0,102	0,0075	145x10 <sup>-6</sup>
1 mbar	100	1	0,001	102x10 <sup>-5</sup>	10,2	0,750	0,0145
1 bar	100.000	1.000	1	1,02	10.200	750	14,5038
1 Kg/cm <sup>2</sup>	98.100	981	0,981	1	10.000	736	14,2233
1 mm c.d.a.	9,81	0,098	9,81x10 <sup>-6</sup>	0,0001	1	0,0736	0,001422
1 mm Hg	133,3	1,33	0,00133	0,001359	13,59	1	0,01934
1 psi	6.895,06	68,95	0,06895	0,07031	703,1	51,717	1

CAUDAL DE AIRE (V)							
	m <sup>3</sup> /h	m <sup>3</sup> /seg	l/h	l/seg	SCFM	SCFH	SCIM
1 m <sup>3</sup> /h	1	2,67x10 <sup>-4</sup>	1.000	0,267	0,59	35,34	1022,5
1 m <sup>3</sup> /seg	3600	2,67x10 <sup>-1</sup>	3,6x10 <sup>6</sup>	1000	2.120	1,27x10 <sup>5</sup>	3,68x10 <sup>6</sup>
1 l/h	0,001	2,67x10 <sup>-7</sup>	1	2,67x10 <sup>-4</sup>	5,9x10 <sup>-4</sup>	35,34x10 <sup>-3</sup>	1,02
1 l/seg	3,6	0,001	3600	1	2,12	127,2	3.670,2
1 SCFM	1,695	4,72x10 <sup>-4</sup>	1.695	0,472	1	60	1.728
1 SCIM	0,98x10 <sup>-3</sup>	2,72x10 <sup>-7</sup>	0,98	2,72x10 <sup>-4</sup>	0,00058	0,0347	1
1 SCFH	0,0283	7,87x10 <sup>-6</sup>	28,30	7,87x10 <sup>-3</sup>	0,0167	1	28,8

POTENCIA								
	W	kW	kgm/s	ch	Hp	kcal/h	BTU/min	BTU/hr
1 W	1	0,001	0,102	1,359x10 <sup>-3</sup>	1,341x10 <sup>-3</sup>	0,860	0,0568	3,41
1 kW	1.000	1	101,97	1,359	1,341	860	56,85	3.413
1 kgm/s	9,81	9,81x10 <sup>-3</sup>	1	0,0133	0,0131	8,424	0,5568	3,34
1 ch	736	0,736	75	1	0,98632	633,6	41,881	2.513
1 Hp	746	0,746	76	1,01387	1	642,4	42,462	2.544
1 kcal/h	1,163	1,163x10 <sup>-3</sup>	0,119	0,00158	0,00156	1	0,0661	3,97
1 BTU/min	17,606	0,0176	1,796	0,0239	0,02355	15,3	1	62,5
1 BTU/hr	0,293	0,293x10 <sup>-3</sup>	0,299	0,398x10 <sup>-3</sup>	0,393x10 <sup>-3</sup>	0,252	0,016	1

### Cálculo del Punto de Trabajo, Revoluciones del Ventilador y Selección del Motor

#### TBS-18/9 motor 2,2 kW

- Caudal (V) = 5.500 m<sup>3</sup>/h
- Presión estática (Pst) = 600 Pa
- Presión dinámica (Pd) = 68 Pa
- Presión total (Pt) = 668 Pa
- Rendimiento (η) = 62 %
- Revoluciones del ventilador (n) = 698 min<sup>-1</sup>
- Potencia motor (Pmot) = 2,2 kW
- Velocidad de impulsión (C) = 10,7 m/s

#### TBS-15/7 motor 3,0 kW

- Caudal (V) = 5.500 m<sup>3</sup>/h
- Presión estática (Pst) = 600 Pa
- Presión dinámica (Pd) = 119 Pa
- Presión total (Pt) = 719 Pa
- Rendimiento (η) = 56%
- Revoluciones del ventilador (n) = 1150 min<sup>-1</sup>
- Potencia motor (Pmot) = 3,0 kW
- Velocidad de impulsión (C) = 14,1 m/s

### Ejemplo de pedido:

Caja seleccionada: TBS-15/7-3,0-RD-90/OR1

Modelo	Tamaño	Posición boca impulsión y oído de aspiración. (Ver pág.14)	Motor kW/Nº Polos	Accesorios	Caudal m <sup>3</sup> /h	Presión Estática	Descarga
						Pa ó mm.c.d.a.	
TBS-S	15/7	RD-90/OR1 (estandar)	3,0/4P	---	5.500	600 Pa	Horizontal
TBS-S	15/7	LG-90/OR9	3,0/4P	---	5.500	600 Pa	
TBS-S	15/7	LG-0/OR15	3,0/4P	---	5.500	600 Pa	
TBS-S	15/7	RD-0/OR7	3,0/4P	---	5.500	600 Pa	Vertical

Caja de ventilación a transmisión simple oído **TBS-S-15/7-3,0-RD-90/OR1**, - Descarga Horizontal - Motor 3 kW 4 Polos 50 Hz. IE2 . Para un caudal de 5.500 m<sup>3</sup>/h y 600 Pa de presión estática.

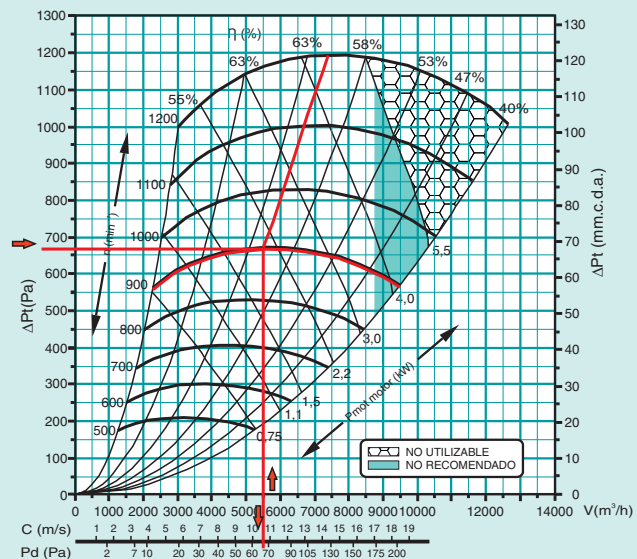
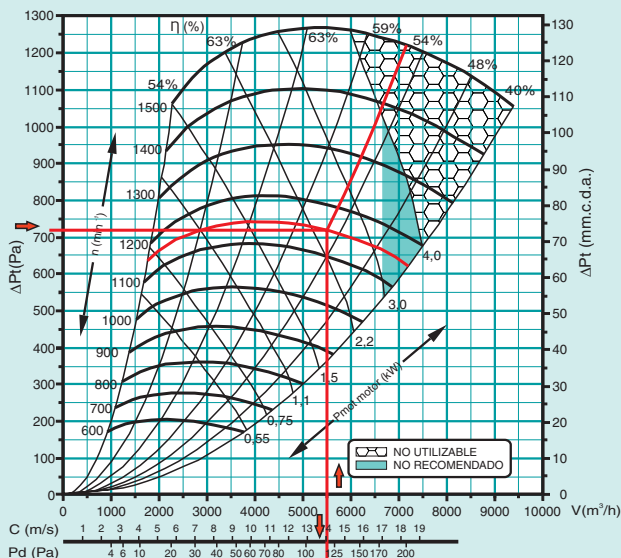

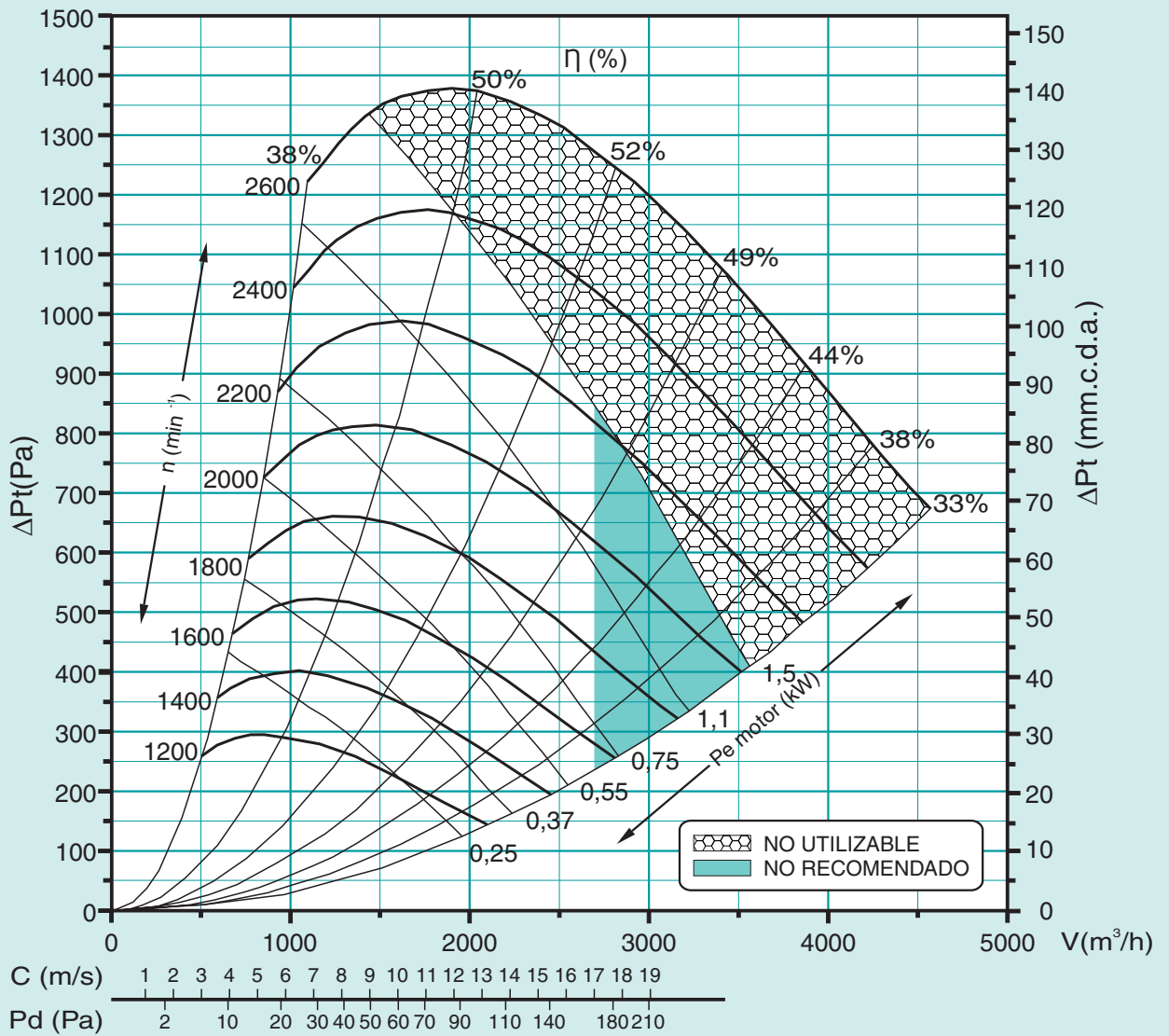
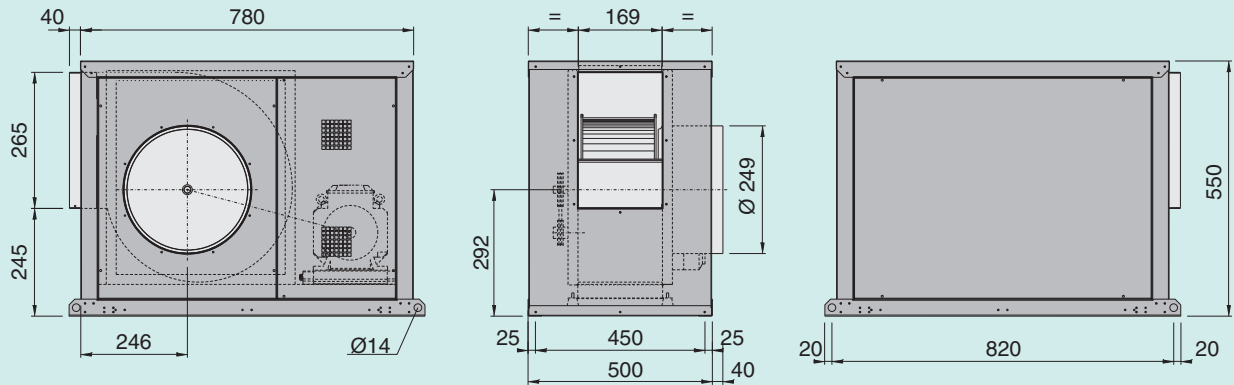

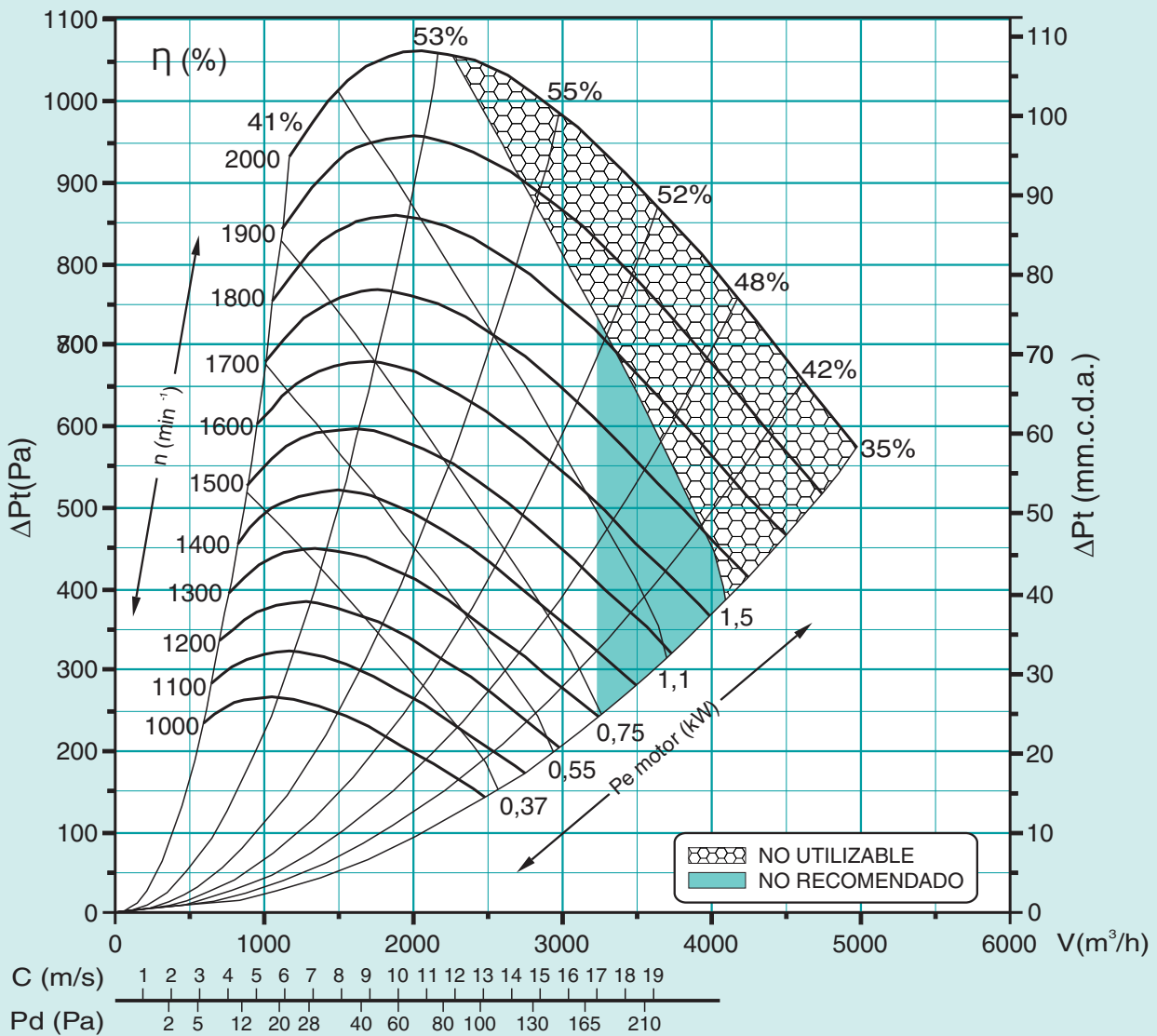
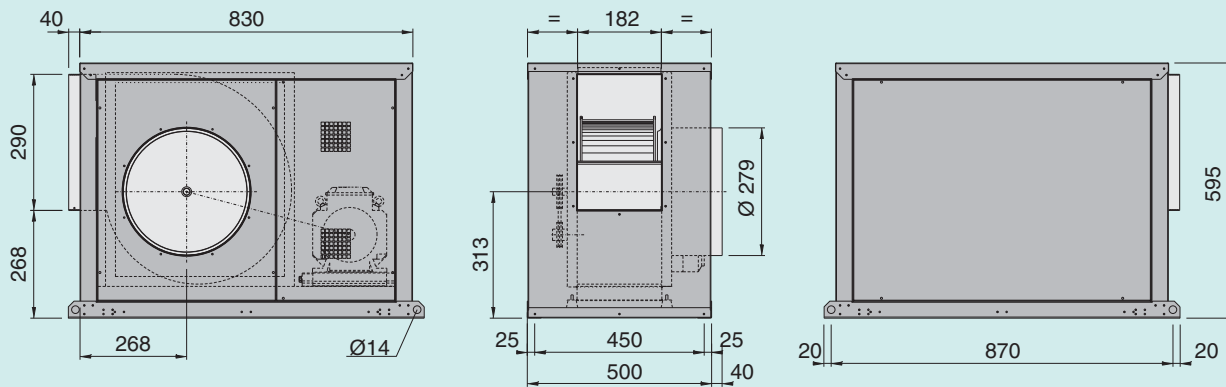

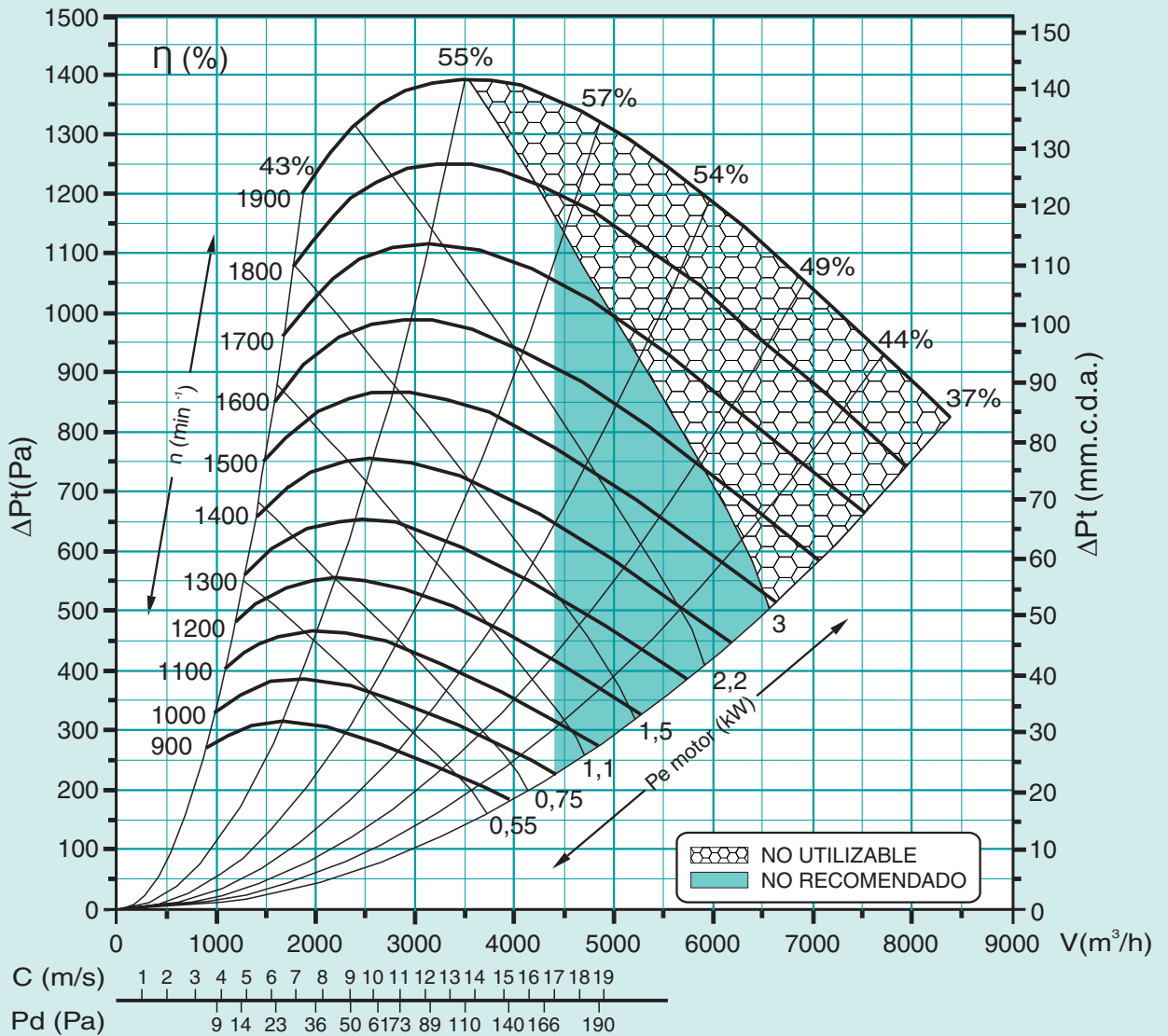
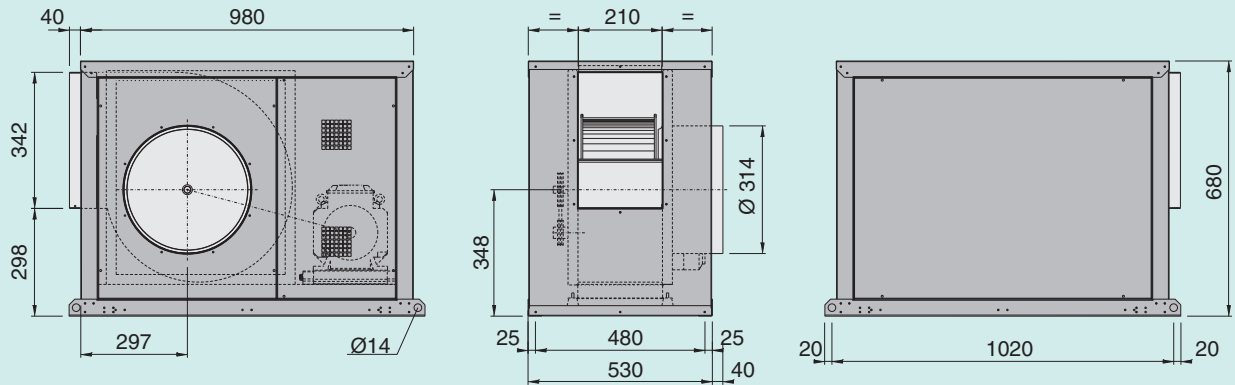

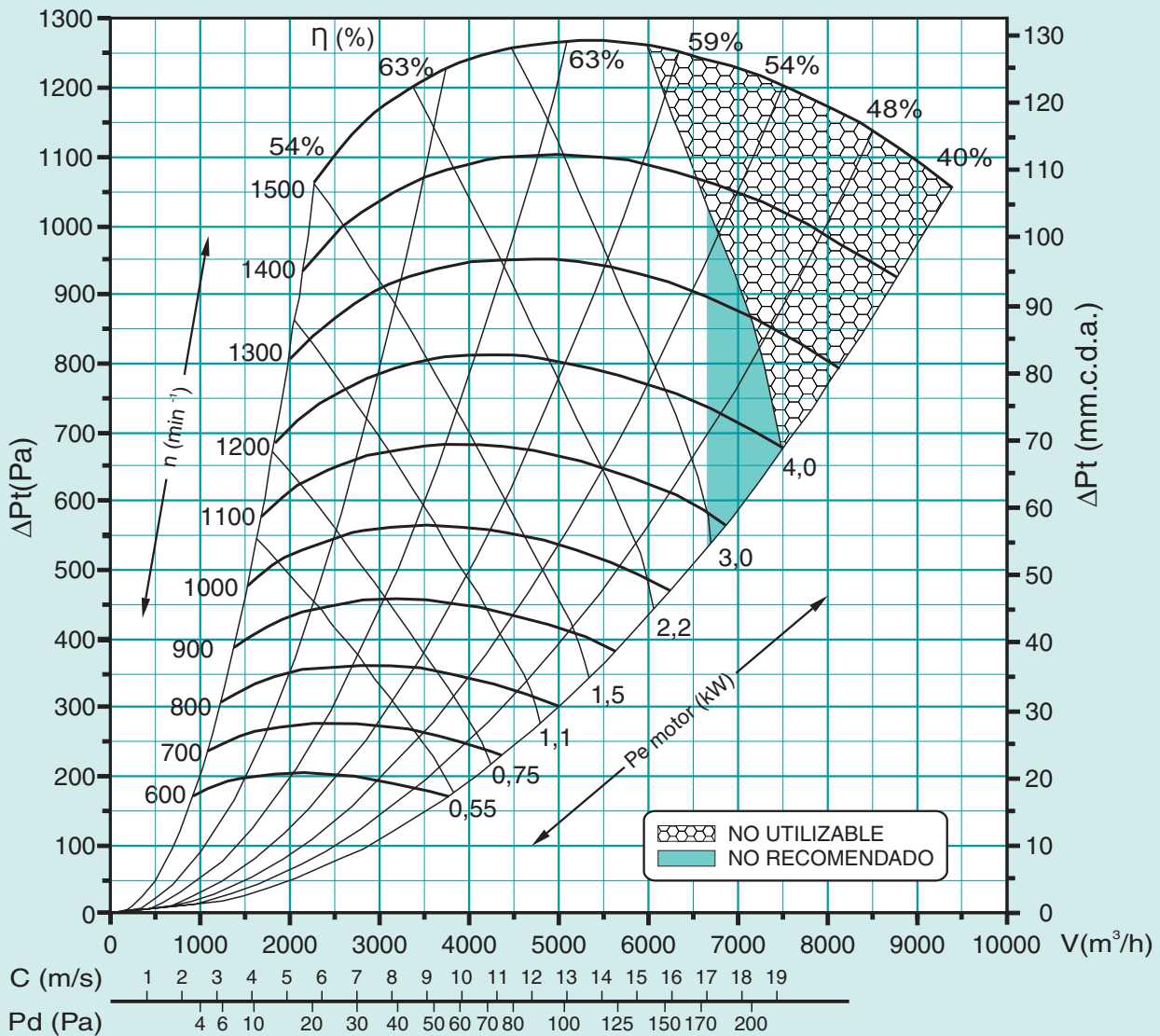
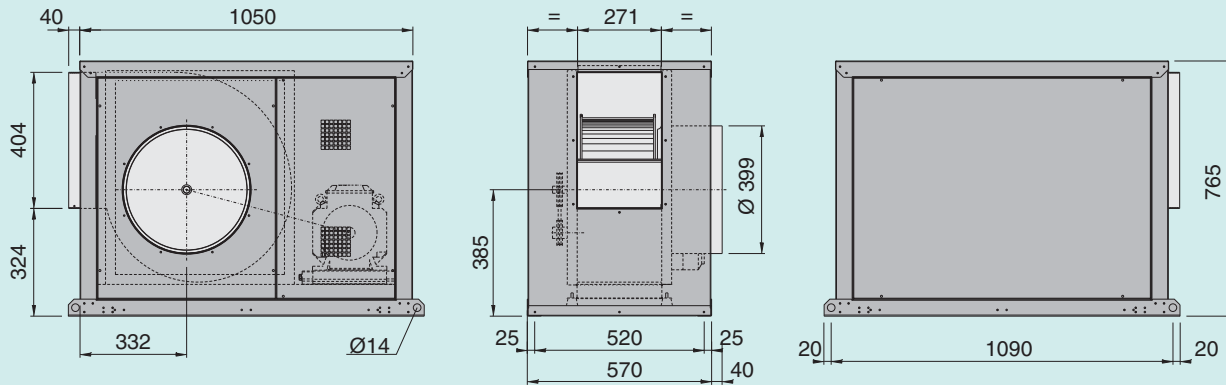

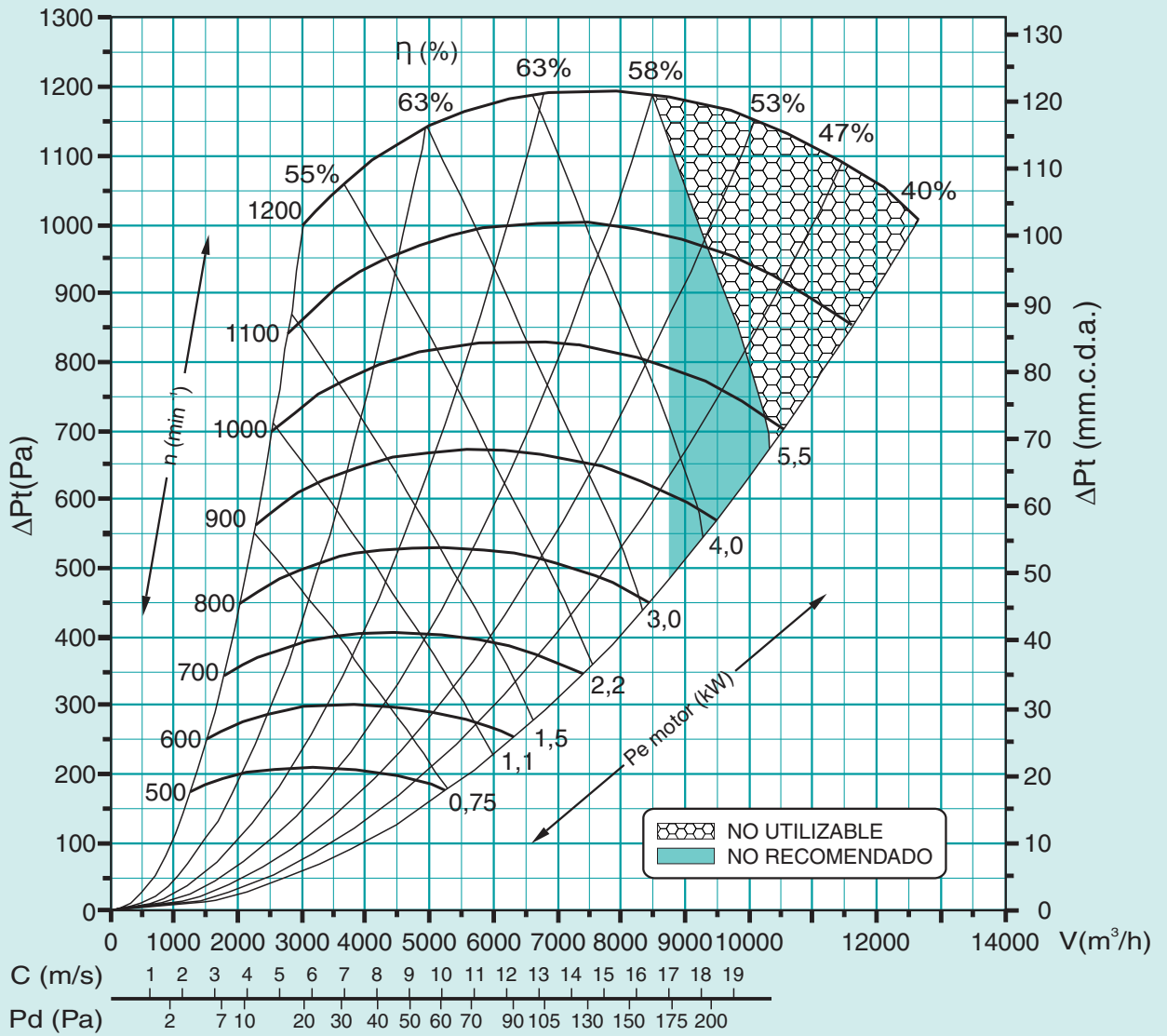
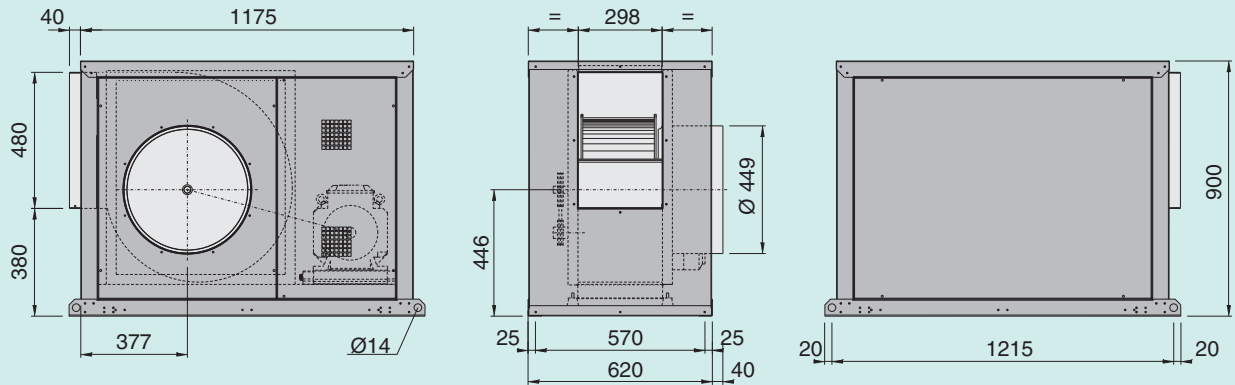

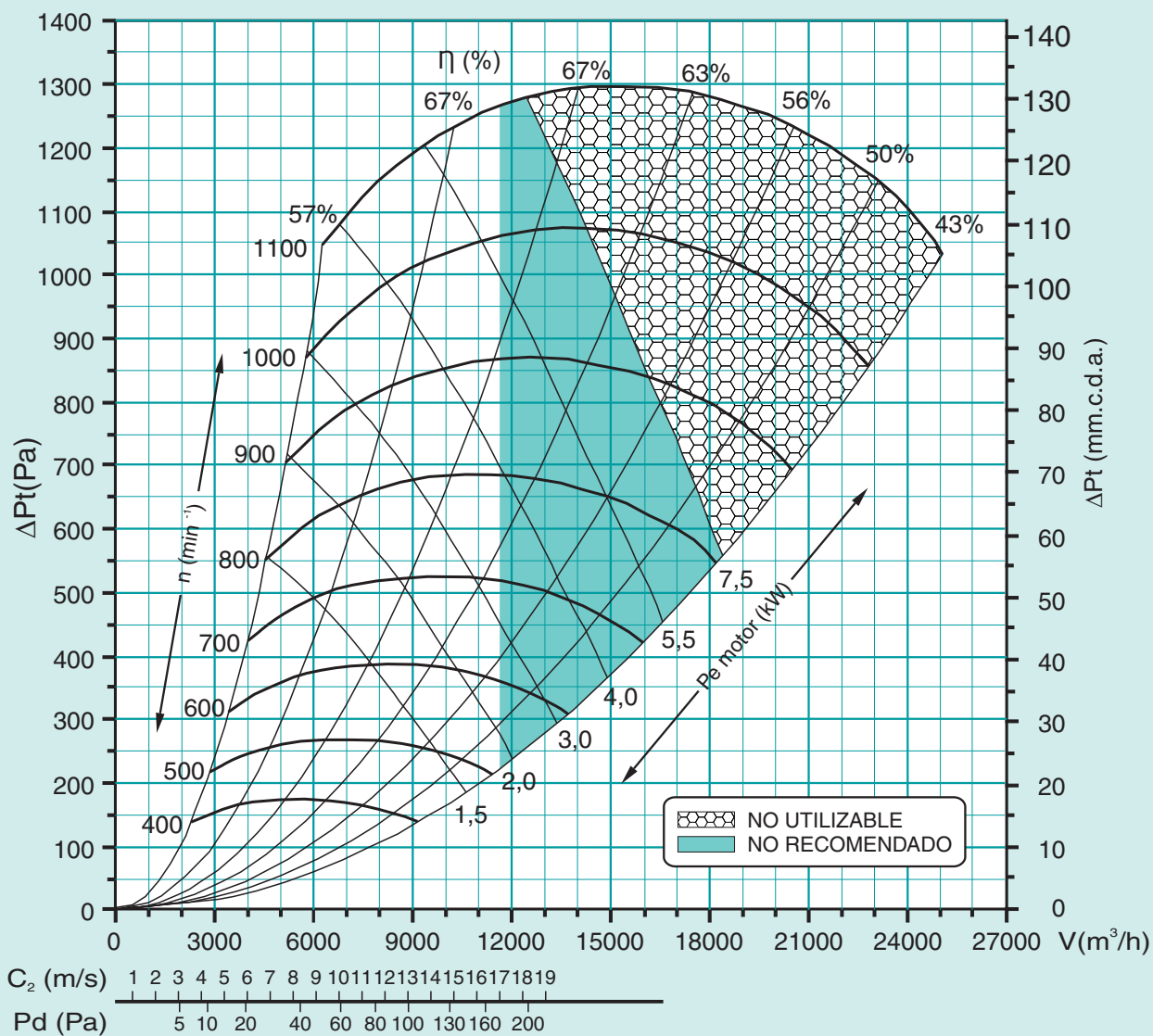
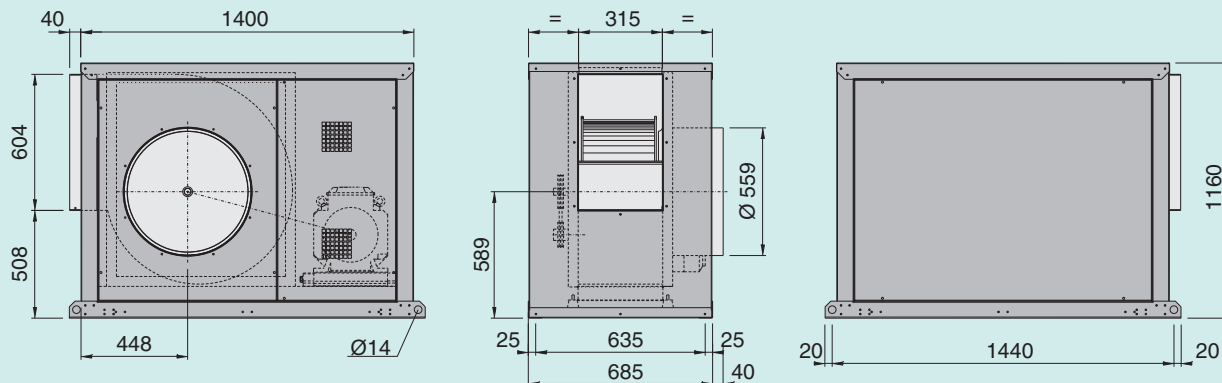

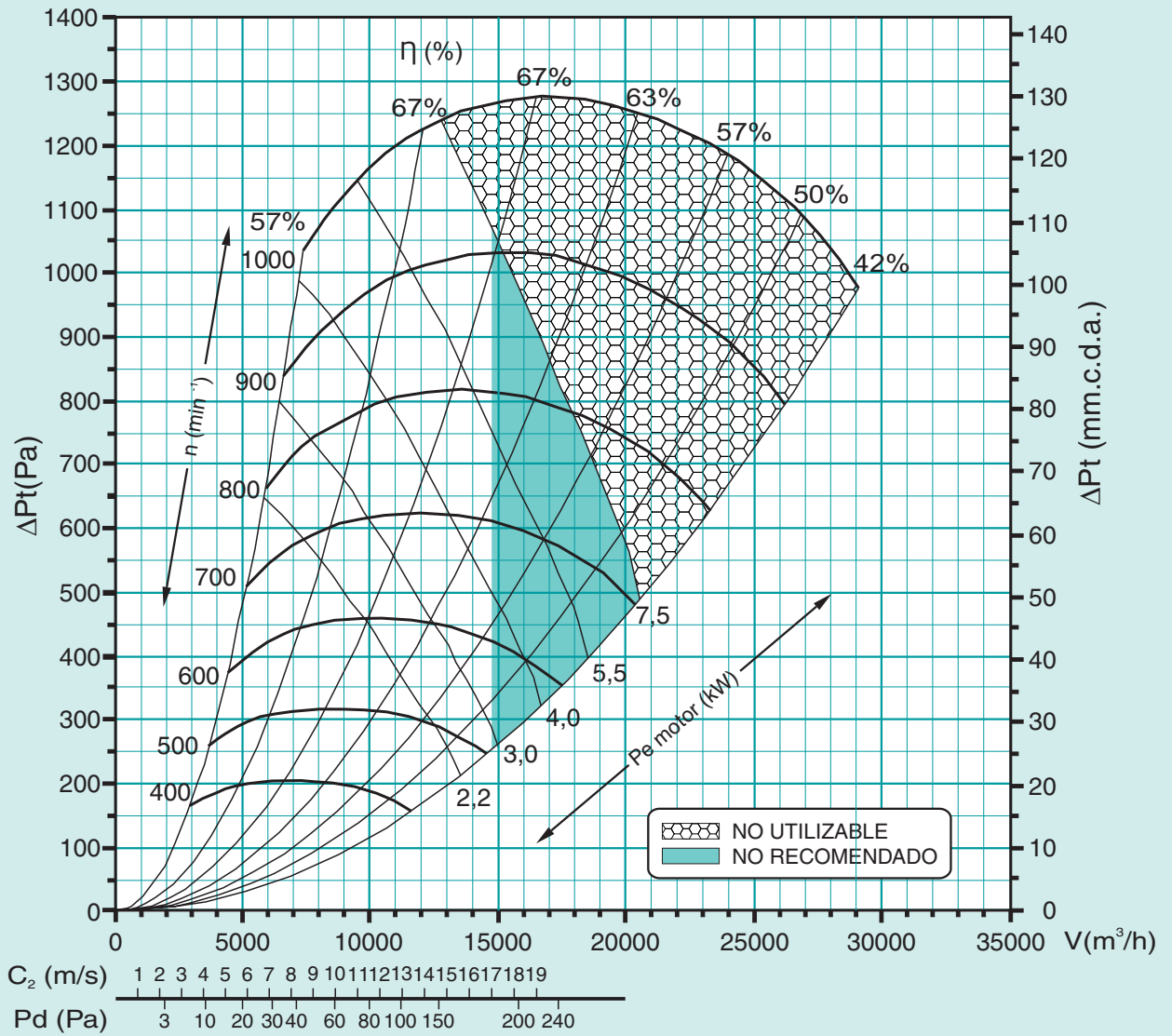
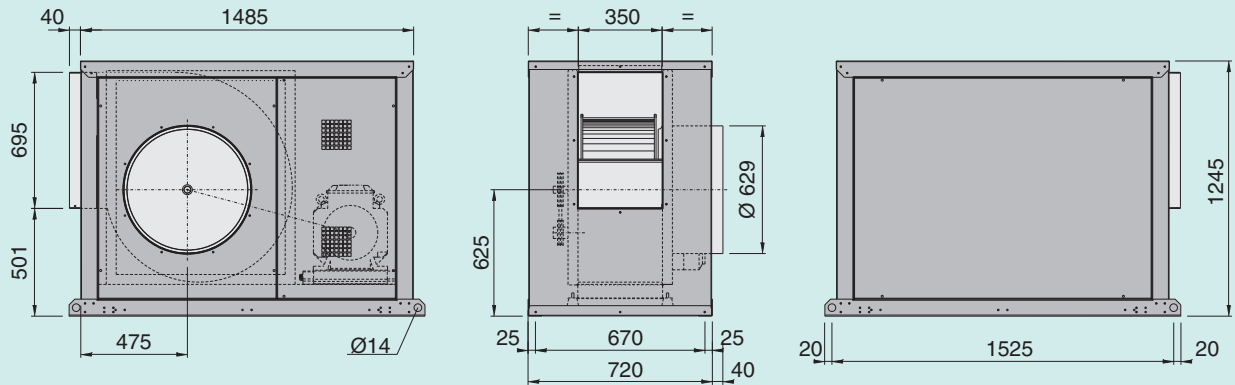

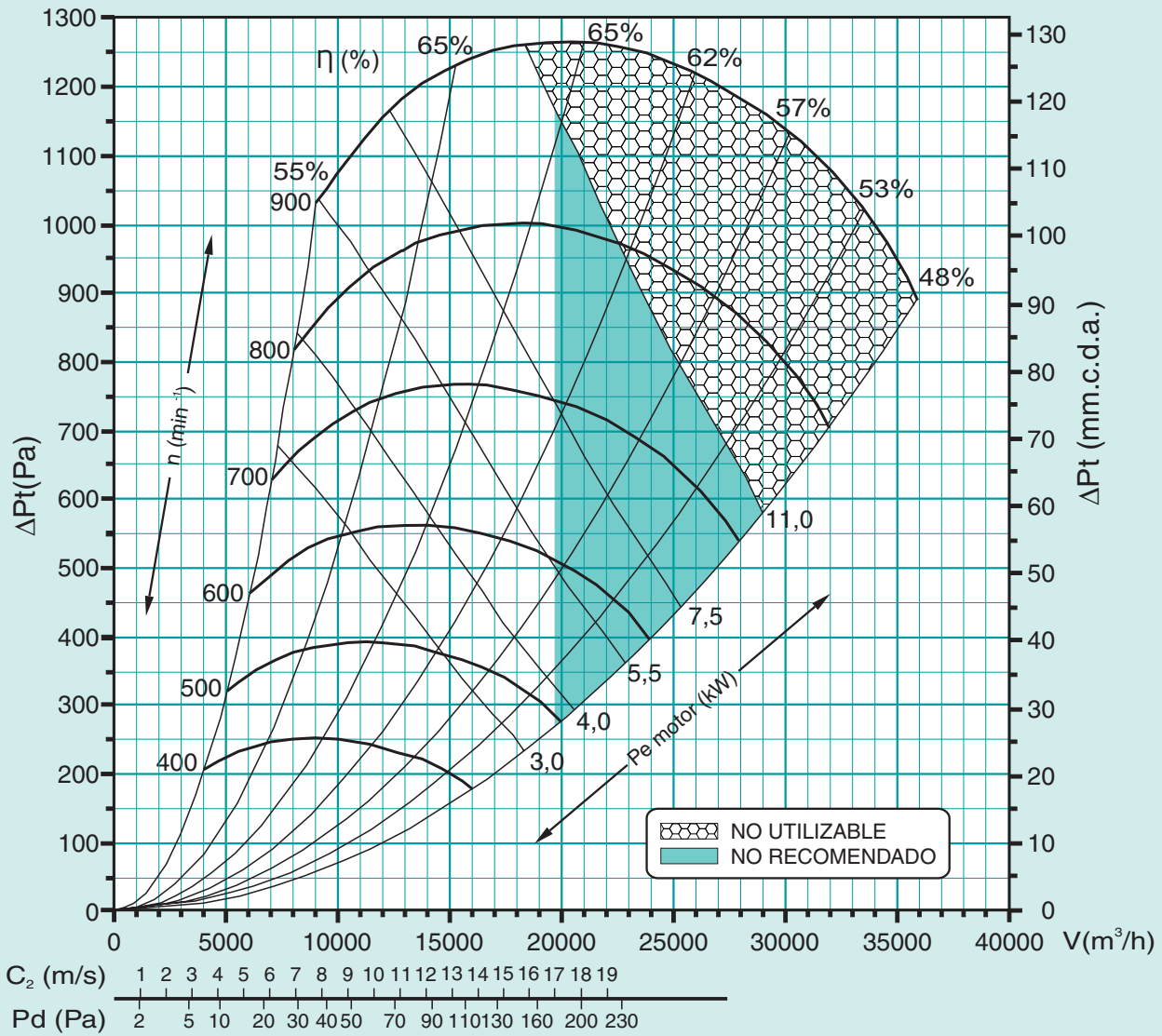
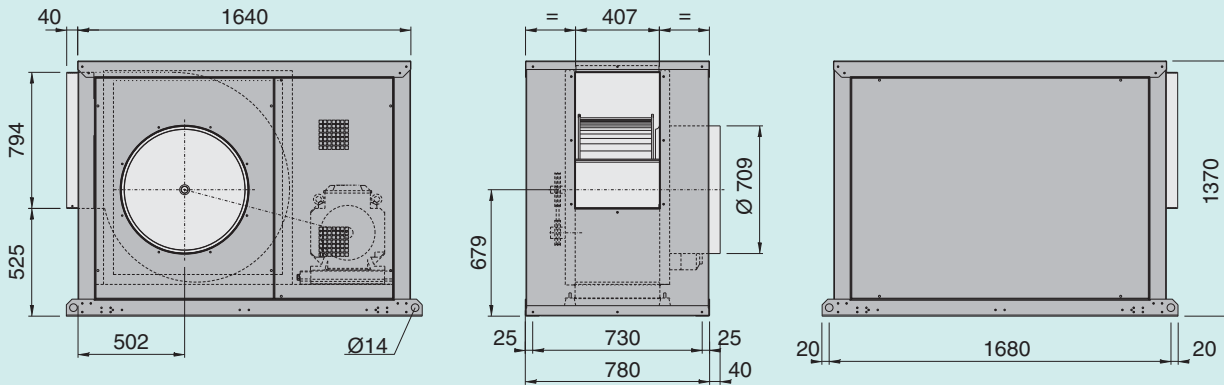

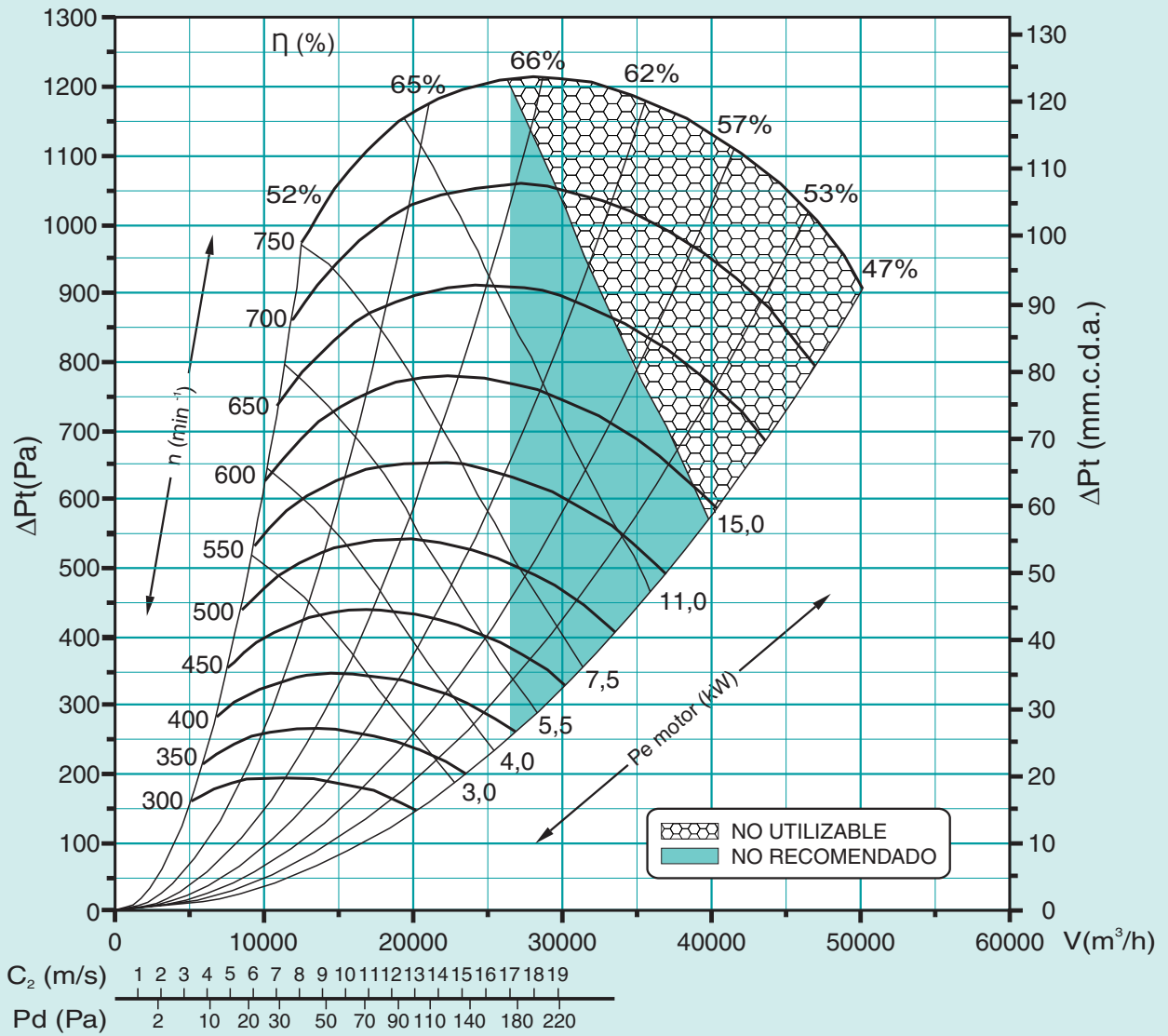
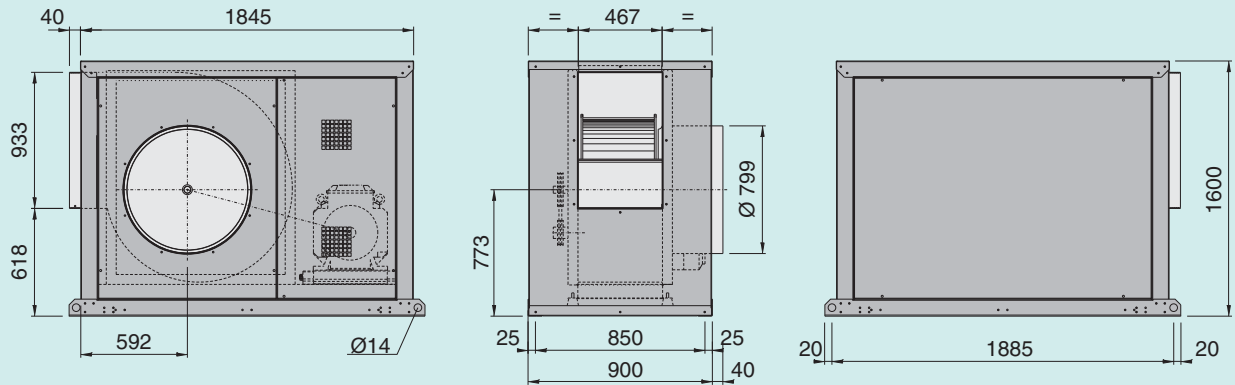

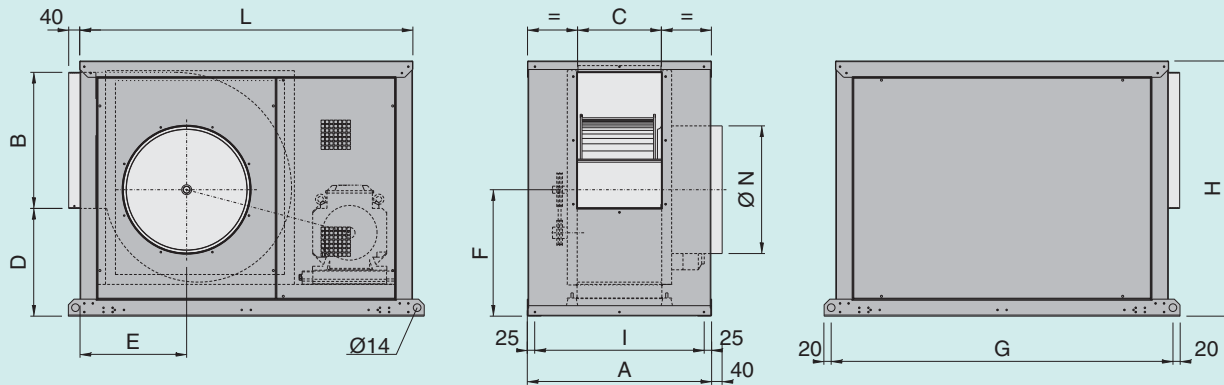

Modelo y Tamaño	Dimensiones Generales (mm)										
	A	B	C	D	E	F	G	H	I	L	ØN
TBS-9/4	500	265	169	245	246	292	820	550	450	780	249
TBS-10/5	500	290	182	268	268	313	870	595	450	830	279
TBS-12/6	530	342	210	298	297	248	1020	680	480	980	314
TBS-15/7	570	404	271	324	332	385	1090	765	520	1050	399
TBS-18/9	620	480	298	380	377	446	1215	900	570	1175	449
TBS-20/10	685	604	315	508	448	589	1440	1160	635	1400	559
TBS-22/11	720	695	350	501	475	625	1525	1245	670	1485	629
TBS-25/13	780	794	407	525	502	679	1680	1370	730	1640	709
TBS-30/14	900	933	467	618	592	773	1885	1600	850	1845	799

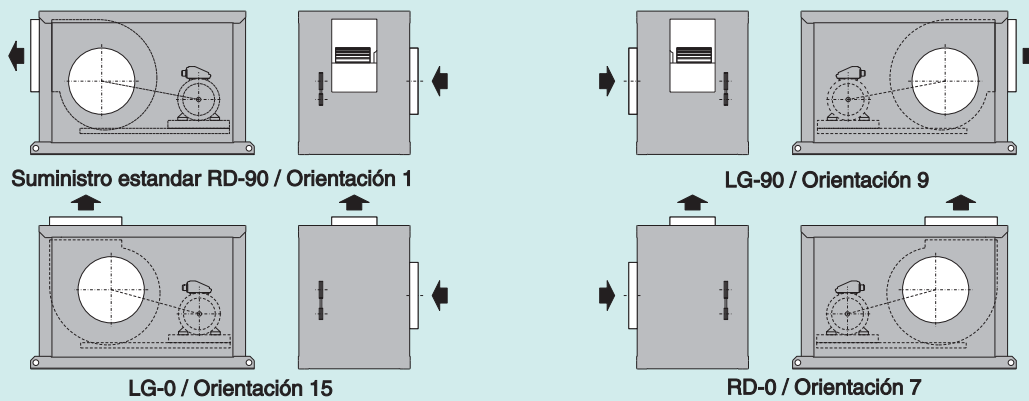

Modelo y Tamaño	Ventilador (Pulgadas)	Gama de Motores Potencia (kW)												
		0,25	0,37	0,55	0,75	1,1	1,5	2,2	3,0	4,0	5,5	7,5	11,0	15,0
TBS-9/4	9/4	(54)	(55)	(57)	(60)	(63)	(67)							
TBS-10/5	10/5		(60)	(62)	(65)	(68)	(72)							
TBS-12/6	12/6			(75)	(78)	(81)	(85)	(92)	(94)					
TBS-15/7	15/7			(88)	(91)	(94)	(98)	(105)	(107)	(117)				
TBS-18/9	18/9				(110)	(113)	(117)	(124)	(126)	(136)	(150)			
TBS-20/10	20/10						(197)	(204)	(206)	(216)	(230)	(243)		
TBS-22/11	22/11							(221)	(223)	(233)	(247)	(260)		
TBS-25/13	25/13								(254)	(264)	(278)	(291)	(354)	
TBS-30/14	30/14								(320)	(330)	(344)	(357)	(420)	(440)

( ) Gama de fabricación y pesos aproximados cajas TBS-F con motor IE2 en Kg.

GAMA MOTORES 4 POLOS 50 Hz IE2									
Potencia (kW)	Carcasa	Velocidad Nominal (min <sup>-1</sup> )	Intensidad						Peso (Kg)
			Nominal (A)			Arranque (A)			
			230 V	400 V	690 V	230 V	400 V	690 V	
0,25	71M	1350	1,5	0,8	---	8,7	5,0	---	5
0,37	71M	1370	1,9	1,1	---	11,6	6,7	---	6
0,55	80M	1410	2,7	1,6	---	11,6	6,7	---	8
0,75	80M	1420	3,1	1,8	---	16,8	9,7	---	11
1,1	90S	1425	4,4	2,5	---	25,7	14,8	---	14
1,5	90L	1420	5,8	3,3	---	36,9	21,3	---	18
2,2	100L	1430	8,0	4,6	---	52,8	30,5	---	23
3,0	100L	1430	11,0	6,4	---	75,8	43,8	---	25
4,0	112M	1435	---	8,4	4,9	---	66,7	38,6	35
5,5	132S	1430	---	11,0	6,4	---	78,4	45,3	49
7,5	132M	1430	---	14,7	8,5	---	114,7	66,3	62
11,0	160M	1440	---	19,4	11,2	---	153,5	88,7	117
15,0	160L	1445	---	25,9	15,0	---	202,2	116,8	137

Nota: Estos valores pueden variar ligeramente en función del fabricante del motor.

GAMA MOTORES 6 POLOS 50 Hz IE2									
Potencia (kW)	Carcasa	Velocidad Nominal (min <sup>-1</sup> )	Intensidad						Peso (Kg)
			Nominal (A)			Arranque (A)			
			230 V	400 V	690 V	230 V	400 V	690 V	
4,0	132M	945	---	8,1	4,7	---	50,3	29,1	52
5,5	132M	945	---	11,3	6,5	---	76,6	44,3	59
7,5	160M	955	---	14,8	8,5	---	103,5	59,8	121
11,0	160L	960	---	21,1	12,2	---	153,7	88,8	139
15,0	180L	960	---	29,1	16,8	---	226,8	131,1	187

Nota: Estos valores pueden variar ligeramente en función del fabricante del motor.

GAMA MOTORES 2 VELOCIDADES 4/8 POLOS 50 Hz IE2							
Potencia 4P/8P (kW)	Carcasa	Velocidad Nominal (min <sup>-1</sup> )	Intensidad 400V 50Hz				Peso (Kg)
			Nominal (A)		Arranque (A)		
			4P	8P	4P	8P	
0,25/0,03	71M	1370/710	1,2	0,5	4,20	1,40	6
0,33/0,04	71M	1360/710	1,5	0,5	6,00	1,50	6,5
0,55/0,09	80M	1410/710	2,0	1,0	9,00	3,50	9,3
0,75/0,12	80M	1430/710	1,8	0,8	12,60	3,20	10
1,1/0,18	90S	1400/710	3,0	1,5	17,40	5,40	14,3
1,5/0,25	90L	1380/700	4,0	1,5	23,20	5,40	17,2
2,2/0,37	100L	1430/720	4,0	2,0	28,00	9,00	23
3,0/0,55	100L	1420/710	6,6	2,5	45,54	10,00	25
4,0/1,0	112M	1440/720	8,5	3,0	63,75	13,50	33
5,5/1,1	132S	1450/720	11,0	4,0	93,50	20,00	40,4
7,5/1,5	132M	1450/720	15,0	5,8	138,00	29,00	48,8
11,0/2,3	160M	1460/720	22,0	8,5	176,00	34,00	85
15,0/3,0	160M	1460/720	28,5	11,5	213,75	46,00	88

GAMA MOTORES 2 VELOCIDADES 4/6 POLOS 50 Hz IE2							
Potencia 4P/6P (kW)	Carcasa	Velocidad Nominal (min <sup>-1</sup> )	Intensidad 400V 50Hz				Peso (Kg)
			Nominal (A)		Arranque (A)		
			4P	6P	4P	6P	
0,25/0,09	71M	1380/950	1,3	0,5	3,90	1,25	6,4
0,37/0,12	80M	1420/960	1,5	0,7	6,75	2,80	9,3
0,55/0,16	80M	1420/960	1,8	0,8	8,10	3,36	10
0,75/0,25	90S	1410/950	2,5	0,9	11,25	3,78	14,3
1,1/0,37	90L	1410/950	3,2	1,5	14,40	6,30	16,5
1,5/0,5	90L	1420/950	4,0	1,6	22,00	8,00	17,2
2,2/0,75	100L	1430/950	5,0	2,4	32,50	10,32	25
3,0/0,9	100L	1430/950	7,5	3,0	45,00	13,80	26
4,0/1,3	132S	1440/960	9,0	4,0	70,20	22,00	40,4
5,5/1,6	132M	1450/970	12,0	4,5	93,60	27,00	47
7,5/2,2	132M	1450/970	15,0	6,2	120,00	34,10	49
11,0/3,3	160M	1460/970	22,0	8,5	176,00	40,80	90
15,0/5,0	160L	1450/970	29,0	12,5	261,00	75,00	120

Nota: Estos valores pueden variar ligeramente en función del fabricante del motor.

Tamaño	Caudal		Vel.Imp. C(m/s)	Pres.Din. Pd(Pa)	Potencia rpm	Presión Estática Pst (Pa)												
	V(m³/h)	V(m³/s)				100	200	300	400	500	600	700	800	900	1000	1100	1200	1300
<b>TBS-9/4</b>	1.450	0,40	9	49	Pe motor(kW)	0,25	0,25	0,37	0,55	0,55	0,75	0,75	1,1	1,1	1,5	1,5	1,5	---
					n (min <sup>-1</sup> )	1010	1200	1360	1510	1650	1790	1920	2040	2160	2280	2390	2500	---
	1.610	0,45	10	60	Pe motor(kW)	0,25	0,37	0,37	0,55	0,75	0,75	1,1	1,1	1,1	1,5	1,5	1,5	---
					n (min <sup>-1</sup> )	1080	1260	1410	1560	1690	1820	1940	2050	2170	2280	2390	2490	---
	1.770	0,49	11	73	Pe motor(kW)	0,25	0,37	0,55	0,55	0,75	1,1	1,1	1,1	1,5	1,5	1,5	---	---
					n (min <sup>-1</sup> )	1150	1320	1470	1600	1730	1850	1970	2080	2190	2290	2400	---	---
	1.930	0,54	12	86	Pe motor(kW)	0,37	0,55	0,55	0,75	0,75	1,1	1,1	1,1	1,5	1,5	---	---	---
					n (min <sup>-1</sup> )	1220	1380	1530	1660	1780	1900	2010	2110	2220	2320	---	---	---
	2.100	0,58	13	101	Pe motor(kW)	0,37	0,55	0,55	0,75	1,1	1,1	1,1	1,5	1,5	1,5	---	---	---
					n (min <sup>-1</sup> )	1300	1450	1590	1710	1830	1940	2050	2150	2250	2350	---	---	---
	2.260	0,63	14	118	Pe motor(kW)	0,55	0,55	0,75	1,1	1,1	1,5	1,5	1,5	---	---	---	---	---
					n (min <sup>-1</sup> )	1370	1520	1650	1770	1900	2100	2200	2290	---	---	---	---	---
	2.420	0,67	15	135	Pe motor(kW)	0,55	0,75	0,75	1,1	1,1	1,5	1,5	1,5	---	---	---	---	---
					n (min <sup>-1</sup> )	1450	1590	1720	1830	1940	2050	2150	2240	---	---	---	---	---
	2.580	0,72	16	154	Pe motor(kW)	0,75	0,75	1,1	1,1	1,5	1,5	1,5	---	---	---	---	---	---
					n (min <sup>-1</sup> )	1520	1660	1780	1900	2000	2100	2200	---	---	---	---	---	---

Tamaño	Caudal		Vel.Imp. C(m/s)	Pres.Din. Pd(Pa)	Potencia rpm	Presión Estática Pst (Pa)												
	V(m³/h)	V(m³/s)				100	200	300	400	500	600	700	800	900	1000	1100	1200	1300
<b>TBS-10/5</b>	1.710	0,48	9	49	Pe motor(kW)	0,37	0,37	0,37	0,55	0,75	0,75	1,1	1,1	1,1	---	---	---	---
					n (min <sup>-1</sup> )	860	1030	1180	1320	1440	1560	1680	1790	1900	---	---	---	---
	1.900	0,53	10	60	Pe motor(kW)	0,37	0,37	0,55	0,55	0,75	1,1	1,1	1,1	1,5	---	---	---	---
					n (min <sup>-1</sup> )	910	1080	1220	1350	1470	1580	1690	1800	1900	---	---	---	---
	2.090	0,58	11	73	Pe motor(kW)	0,37	0,37	0,55	0,75	0,75	1,1	1,1	1,5	1,5	---	---	---	---
					n (min <sup>-1</sup> )	970	1130	1260	1390	1500	1610	1720	1820	1920	---	---	---	---
	2.280	0,63	12	86	Pe motor(kW)	0,37	0,55	0,55	0,75	1,1	1,1	1,1	1,5	1,5	---	---	---	---
					n (min <sup>-1</sup> )	1030	1180	1310	1430	1540	1640	1740	1840	1940	---	---	---	---
	2.470	0,69	13	101	Pe motor(kW)	0,55	0,55	0,75	1,1	1,1	1,1	1,5	1,5	---	---	---	---	---
					n (min <sup>-1</sup> )	1090	1230	1360	1470	1580	1680	1780	1870	---	---	---	---	---
	2.660	0,74	14	118	Pe motor(kW)	0,55	0,75	0,75	1,1	1,1	1,5	1,5	1,5	---	---	---	---	---
					n (min <sup>-1</sup> )	1150	1290	1410	1520	1620	1720	1810	1900	---	---	---	---	---
	2.850	0,79	15	135	Pe motor(kW)	0,55	0,75	1,1	1,1	1,5	1,5	1,5	---	---	---	---	---	---
					n (min <sup>-1</sup> )	1210	1340	1460	1560	1660	1760	1850	---	---	---	---	---	---
	3.040	0,84	16	154	Pe motor(kW)	0,75	1,1	1,1	1,1	1,5	1,5	---	---	---	---	---	---	---
					n (min <sup>-1</sup> )	1270	1400	1510	1610	1710	1800	---	---	---	---	---	---	---

Tamaño	Caudal		Vel.Imp. C(m/s)	Pres.Din. Pd(Pa)	Potencia rpm	Presión Estática Pst (Pa)												
	V(m³/h)	V(m³/s)				100	200	300	400	500	600	700	800	900	1000	1100	1200	1300
<b>TBS-12/6</b>	2.330	0,65	9	49	Pe motor(kW)	0,55	0,55	0,75	0,75	1,1	1,1	1,1	1,5	1,5	1,5	2,2	2,2	2,2
					n (min <sup>-1</sup> )	590	680	770	850	920	990	1060	1130	1190	1250	1300	1360	1410
	2.590	0,72	10	60	Pe motor(kW)	0,55	0,75	0,75	1,1	1,1	1,1	1,5	1,5	1,5	2,2	2,2	2,2	2,2
					n (min <sup>-1</sup> )	620	700	780	860	930	1000	1060	1130	1190	1250	1300	1360	1410
	2.850	0,79	11	73	Pe motor(kW)	0,75	0,75	1,1	1,1	1,1	1,5	1,5	2,2	2,2	2,2	2,2	2,2	3,0
					n (min <sup>-1</sup> )	650	720	800	870	940	1010	1070	1130	1190	1250	1300	1350	1420
	3.110	0,86	12	86	Pe motor(kW)	0,75	1,1	1,1	1,1	1,5	1,5	2,2	2,2	2,2	2,2	2,2	3,0	3,0
					n (min <sup>-1</sup> )	680	750	820	890	950	1020	1080	1140	1190	1250	1300	1370	1420
	3.370	0,94	13	101	Pe motor(kW)	1,1	1,1	1,5	1,5	1,5	2,2	2,2	2,2	2,2	3,0	3,0	3,0	3,0
					n (min <sup>-1</sup> )	710	780	840	910	970	1030	1090	1150	1200	1270	1320	1370	1420
	3.630	1,01	14	118	Pe motor(kW)	0,75	1,1	1,1	1,5	1,5	2,2	2,2	2,2	2,2	3,0	3,0	3,0	---
					n (min <sup>-1</sup> )	910	1030	1130	1230	1320	1400	1480	1560	1640	1710	1780	1850	---
	3.890	1,08	15	135	Pe motor(kW)	0,75	1,1	1,1	1,5	1,5	2,2	2,2	2,2	3,0	3,0	3,0	---	---
					n (min <sup>-1</sup> )	950	1070	1170	1260	1350	1430	1510	1590	1660	1730	1800	---	---
	4.150	1,15	16	154	Pe motor(kW)	1,1	1,1	1,5	1,5	2,2	2,2	2,2	3,0	3,0	3,0	---	---	---
					n (min <sup>-1</sup> )	1000	1110	1210	1300	1380	1460	1540	1610	1680	1750	---	---	---

Selección Silenciosa   
  Selección Estandar   
  Selección Industrial

Tamaño	Caudal		Vel.Imp. C <sub>2</sub> (m/s)	Pres.Din(Pd) Pd(Pa)	Potencia rpm	Presión Estática Pst (Pa)												
	V(m³/h)	V(m³/s)				100	200	300	400	500	600	700	800	900	1000	1100	1200	1300
<b>TBS-15/7</b>	3.520	0,98	9	49	Pe motor(kW)	0,55	0,55	0,75	1,1	1,1	1,5	1,5	2,2	2,2	2,2	2,2	---	---
					n (min <sup>-1</sup> )	560	680	790	890	990	1070	1150	1230	1310	1380	1450	---	---
	3.910	1,09	10	60	Pe motor(kW)	---	0,75	1,1	1,1	1,5	1,5	2,2	2,2	2,2	2,2	3,0	---	---
					n (min <sup>-1</sup> )	---	710	810	910	1000	1080	1160	1240	1310	1380	1450	---	---
	4.300	1,19	11	73	Pe motor(kW)	---	1,1	1,1	1,5	1,5	2,2	2,2	2,2	3,0	3,0	3,0	---	---
					n (min <sup>-1</sup> )	---	740	840	930	1010	1090	1170	1240	1310	1380	1450	---	---
	4.690	1,30	12	86	Pe motor(kW)	---	1,1	1,5	1,5	2,2	2,2	2,2	3,0	3,0	3,0	3,0	---	---
					n (min <sup>-1</sup> )	---	770	860	950	1030	1110	1180	1250	1320	1390	1450	---	---
	5.090	1,41	13	101	Pe motor(kW)	---	---	1,5	2,2	2,2	2,2	3,0	3,0	3,0	4,0	4,0	---	---
					n (min <sup>-1</sup> )	---	---	890	970	1050	1130	1200	1270	1330	1400	1460	---	---
	5.480	1,52	14	118	Pe motor(kW)	---	---	2,2	2,2	2,2	3,0	3,0	3,0	4,0	4,0	4,0	---	---
					n (min <sup>-1</sup> )	---	---	920	1000	1080	1150	1220	1280	1350	1410	1470	---	---
	5.870	1,63	15	135	Pe motor(kW)	---	---	2,2	2,2	3,0	3,0	3,0	4,0	4,0	4,0	---	---	
					n (min <sup>-1</sup> )	---	---	950	1030	1100	1170	1240	1300	1370	1430	1480	---	---
	6.260	1,74	16	154	Pe motor(kW)	---	---	---	3,0	3,0	4,0	4,0	4,0	4,0	---	---	---	
					n (min <sup>-1</sup> )	---	---	---	1060	1130	1200	1260	1320	1380	1440	---	---	

Tamaño	Caudal		Vel.Imp. C <sub>2</sub> (m/s)	Pres.Din(Pd) Pd(Pa)	Potencia rpm	Presión Estática Pst (Pa)												
	V(m³/h)	V(m³/s)				100	200	300	400	500	600	700	800	900	1000	1100	1200	1300
<b>TBS-18/9</b>	4.630	1,29	9,0	49	Pe motor(kW)	0,75	0,75	1,1	1,5	1,5	2,2	2,2	2,2	3,0	3,0	---	---	---
					n (min <sup>-1</sup> )	450	560	650	730	810	890	960	1030	1090	1150	---	---	---
	5.150	1,43	10,0	60	Pe motor(kW)	---	1,1	1,5	1,5	2,2	2,2	2,2	3,0	3,0	3,0	---	---	---
					n (min <sup>-1</sup> )	---	580	660	750	820	890	960	1030	1090	1150	---	---	---
	5.660	1,57	11,0	73	Pe motor(kW)	---	1,1	1,5	2,2	2,2	2,2	3,0	3,0	3,0	4,0	---	---	---
					n (min <sup>-1</sup> )	---	600	680	760	830	900	970	1030	1090	1150	---	---	---
	8.180	1,72	12,0	86	Pe motor(kW)	---	1,5	2,2	2,2	2,2	3,0	3,0	3,0	4,0	4,0	---	---	---
					n (min <sup>-1</sup> )	---	620	700	770	840	910	970	1030	1090	1150	---	---	---
	6.690	1,86	13,0	101	Pe motor(kW)	---	2,2	2,2	2,2	3,0	3,0	3,0	4,0	4,0	4,0	---	---	---
					n (min <sup>-1</sup> )	---	650	720	790	860	920	980	1040	1100	1150	---	---	---
	7.210	2,00	14,0	118	Pe motor(kW)	---	---	2,2	3,0	3,0	4,0	4,0	4,0	4,0	5,5	---	---	---
					n (min <sup>-1</sup> )	---	---	740	810	870	940	1000	1050	1110	1160	---	---	---
	7.720	2,14	15,0	135	Pe motor(kW)	---	---	3,0	3,0	4,0	4,0	4,0	4,0	5,5	5,5	---	---	---
					n (min <sup>-1</sup> )	---	---	770	830	890	950	1010	1060	1120	1170	---	---	---
	8.240	2,29	16,0	154	Pe motor(kW)	---	---	3,0	4,0	4,0	4,0	5,5	5,5	5,5	5,5	---	---	---
					n (min <sup>-1</sup> )	---	---	800	850	910	970	1030	1080	1130	1180	---	---	---

Tamaño	Caudal		Vel.Imp. C <sub>2</sub> (m/s)	Pres.Din(Pd) Pd(Pa)	Potencia rpm	Presión Estática Pst (Pa)												
	V(m³/h)	V(m³/s)				100	200	300	400	500	600	700	800	900	1000	1100	1200	1300
<b>TBS-20/10</b>	6.160	1,71	9	49	Pe motor(kW)	1,5	1,5	1,5	1,5	1,5	2,2	3,0	3,0	4,0	---	---	---	---
					n (min <sup>-1</sup> )	370	480	580	620	710	800	900	970	1040	---	---	---	---
	6.850	1,90	10	60	Pe motor(kW)	1,5	1,5	1,5	2,2	2,2	3,0	3,0	4,0	4,0	4,0	---	---	---
					n (min <sup>-1</sup> )	390	490	580	660	740	810	890	950	1020	1080	---	---	---
	7.53	2,09	11	73	Pe motor(kW)	1,5	1,5	1,5	2,2	2,2	3,0	3,0	4,0	4,0	5,5	---	---	---
					n (min <sup>-1</sup> )	410	500	590	670	740	810	880	940	1010	1070	---	---	---
	8.220	2,28	12	86	Pe motor(kW)	1,5	1,5	2,2	2,2	3,0	3,0	4,0	4,0	4,0	5,5	---	---	---
					n (min <sup>-1</sup> )	430	520	600	670	750	810	880	940	1000	1060	---	---	---
	8.900	2,47	13	101	Pe motor(kW)	1,5	1,5	2,2	3,0	3,0	4,0	4,0	4,0	5,5	5,5	---	---	---
					n (min <sup>-1</sup> )	450	530	610	680	750	820	880	940	1000	1050	---	---	---
	8.590	2,66	14	118	Pe motor(kW)	1,5	2,2	2,2	3,0	3,0	4,0	4,0	5,5	5,5	5,5	---	---	---
					n (min <sup>-1</sup> )	470	550	620	690	760	820	880	940	1000	1050	---	---	---
	10.270	2,85	15	135	Pe motor(kW)	2,2	2,2	3,0	3,0	4,0	4,0	5,5	5,5	5,5	7,5	---	---	---
					n (min <sup>-1</sup> )	490	570	640	710	770	830	890	940	1000	1050	---	---	---
	10.960	3,04	16	154	Pe motor(kW)	2,2	3,0	3,0	4,0	4,0	4,0	5,5	5,5	5,5	7,5	---	---	---
					n (min <sup>-1</sup> )	520	590	650	720	780	840	890	950	1000	1050	---	---	---

Selección Silenciosa   
  Selección Estandar   
  Selección Industrial

Tamaño	Caudal		Vel.Imp. C <sub>2</sub> (m/s)	Pres.Din(Pd) Pd(Pa)	Potencia rpm	Presión Estática Pst (Pa)												
	V(m³/h)	V(m³/s)				100	200	300	400	500	600	700	800	900	1000	1100	1200	1300
<b>TBS-22/11</b>	7.800	2,17	9	49	Pe motor(kW)	2,2	2,2	2,2	2,2	2,2	3,0	4,0	4,0	4,0	5,5	---	---	---
					n (min <sup>-1</sup> )	350	440	520	600	670	740	800	870	930	990	---	---	---
	8.670	2,41	10	60	Pe motor(kW)	2,2	2,2	2,2	2,2	3,0	3,0	4,0	4,0	5,5	5,5	---	---	---
					n (min <sup>-1</sup> )	370	450	530	600	670	730	800	860	910	970	---	---	---
	9.540	2,65	11	73	Pe motor(kW)	2,2	2,2	2,2	3,0	3,0	4,0	4,0	5,5	5,5	5,5	---	---	---
					n (min <sup>-1</sup> )	380	470	540	610	670	730	790	850	910	960	---	---	---
	10.400	2,89	12	86	Pe motor(kW)	2,2	2,2	2,2	3,0	3,0	4,0	4,0	5,5	5,5	5,5	---	---	---
					n (min <sup>-1</sup> )	400	480	550	620	680	740	790	850	900	960	---	---	---
	11.270	3,13	13	101	Pe motor(kW)	2,2	2,2	3,0	3,0	4,0	4,0	5,5	5,5	5,5	7,5	7,5	---	---
					n (min <sup>-1</sup> )	430	500	560	630	690	740	800	850	900	950	1000	---	---
	12.140	3,37	14	118	Pe motor(kW)	2,2	3,0	3,0	4,0	4,0	5,5	5,5	5,5	7,5	7,5	7,5	---	---
					n (min <sup>-1</sup> )	450	510	580	650	700	750	800	850	900	950	990	---	---
	13.000	3,61	15	135	Pe motor(kW)	2,2	3,0	4,0	4,0	5,5	5,5	5,5	7,5	7,5	7,5	---	---	---
					n (min <sup>-1</sup> )	470	530	590	650	710	760	810	860	900	950	---	---	---
	13.870	3,85	16	154	Pe motor(kW)	3,0	3,0	4,0	4,0	5,5	5,5	7,5	7,5	7,5	---	---	---	---
					n (min <sup>-1</sup> )	490	550	610	670	720	770	820	860	910	---	---	---	---

Tamaño	Caudal		Vel.Imp. C <sub>2</sub> (m/s)	Pres.Din(Pd) Pd(Pa)	Potencia rpm	Presión Estática Pst (Pa)													
	V(m³/h)	V(m³/s)				100	200	300	400	500	600	700	800	900	1000	1100	1200	1300	
<b>TBS-25/13</b>	10.440	2,90	9	49	Pe motor(kW)	3,0	3,0	3,0	3,0	3,0	4,0	4,0	5,5	5,5	7,5	---	---	---	
					n (min <sup>-1</sup> )	320	400	470	540	600	660	710	770	820	870	---	---	---	
	11.600	3,22	10	60	Pe motor(kW)	3,0	3,0	3,0	3,0	4,0	4,0	5,5	5,5	7,5	7,5	---	---	---	
					n (min <sup>-1</sup> )	340	410	480	540	600	660	710	760	810	860	---	---	---	
	12.760	3,54	11	73	Pe motor(kW)	3,0	3,0	3,0	4,0	4,0	5,5	5,5	7,5	7,5	7,5	11,0	---	---	
					n (min <sup>-1</sup> )	360	430	490	550	600	660	710	760	810	850	900	---	---	
	13.920	3,87	12	86	Pe motor(kW)	3,0	3,0	3,0	4,0	4,0	5,5	5,5	7,5	7,5	7,5	11,0	11,0	---	---
					n (min <sup>-1</sup> )	380	440	500	560	610	660	710	760	800	850	890	---	---	
	15.090	4,19	13	101	Pe motor(kW)	3,0	3,0	4,0	4,0	5,5	5,5	7,5	7,5	7,5	11,0	11,0	---	---	
					n (min <sup>-1</sup> )	400	460	520	570	620	670	720	770	800	850	890	---	---	
	16.250	4,51	14	118	Pe motor(kW)	3,0	4,0	4,0	5,5	5,5	7,5	7,5	7,5	11,0	11,0	11,0	---	---	
					n (min <sup>-1</sup> )	420	480	530	580	630	680	720	770	810	850	890	---	---	
	17.410	4,84	15	135	Pe motor(kW)	3,0	4,0	5,5	5,5	7,5	7,5	7,5	11,0	11,0	11,0	11,0	---	---	
					n (min <sup>-1</sup> )	450	500	550	600	640	690	730	770	810	850	890	---	---	
	18.570	5,16	16	154	Pe motor(kW)	4,0	4,0	5,5	5,5	7,5	7,5	11,0	11,0	11,0	11,0	---	---	---	
					n (min <sup>-1</sup> )	470	520	560	610	660	700	740	780	820	860	---	---	---	

Tamaño	Caudal		Vel.Imp. C <sub>2</sub> (m/s)	Pres.Din(Pd) Pd(Pa)	Potencia rpm	Presión Estática Pst (Pa)												
	V(m³/h)	V(m³/s)				100	200	300	400	500	600	700	800	900	1000	1100	1200	1300
<b>TBS-30/14</b>	14.010	3,89	9	49	Pe motor(kW)	3,0	3,0	3,0	4,0	4,0	5,5	7,5	7,5	7,5	---	---	---	
					n (min <sup>-1</sup> )	270	340	400	460	510	570	620	660	410	---	---	---	
	15.570	4,33	10	60	Pe motor(kW)	3,0	3,0	3,0	4,0	5,5	5,5	7,5	7,5	11,0	11,0	---	---	
					n (min <sup>-1</sup> )	280	350	410	460	510	560	610	660	700	750	---	---	
	17.120	4,76	11	73	Pe motor(kW)	3,0	3,0	4,0	4,0	5,5	7,5	7,5	7,5	11,0	11,0	---	---	
					n (min <sup>-1</sup> )	300	360	420	470	520	560	610	650	690	730	---	---	
	18.680	5,19	12	86	Pe motor(kW)	3,0	3,0	4,0	5,5	5,5	7,5	7,5	11,0	11,0	---	---	---	
					n (min <sup>-1</sup> )	310	370	420	470	520	560	610	650	690	730	---	---	
	20.240	5,62	13	101	Pe motor(kW)	3,0	4,0	5,5	5,5	7,5	7,5	11,0	11,0	11,0	15,0	---	---	
					n (min <sup>-1</sup> )	330	380	440	480	530	570	610	650	690	730	---	---	
	21.790	6,05	14	118	Pe motor(kW)	4,0	4,0	5,5	7,5	7,5	11,0	11,0	11,0	11,0	15,0	---	---	
					n (min <sup>-1</sup> )	350	400	450	490	530	580	620	650	690	730	---	---	
	23.350	6,49	15	135	Pe motor(kW)	4,0	5,5	5,5	7,5	7,5	11,0	11,0	11,0	15,0	15,0	---	---	
					n (min <sup>-1</sup> )	370	410	460	500	540	580	620	660	690	730	---	---	
	24.910	6,92	16	154	Pe motor(kW)	5,5	5,5	7,5	7,5	11,0	11,0	11,0	15,0	15,0	15,0	---	---	
					n (min <sup>-1</sup> )	380	430	470	510	550	590	630	660	700	730	---	---	

Selección Silenciosa   
  Selección Estandar   
  Selección Industrial

### Curvas de características

Las curvas de características han sido determinadas para una temperatura de aire de 20° C y una presión barométrica de 760 mm Hg, equivalente a una densidad de 1,2 Kg/m<sup>3</sup>.

Cualquier variación de estos valores implica la utilización de los coeficientes de corrección indicados en la tabla n°. 1

### Ejemplo de aplicación:

Según las leyes de los ventiladores relativas a la variación de la densidad del aire, tenemos:

a) El caudal en volumen permanece invariable.  $V_1 = V_2$

b) La presión y la potencia absorbida a igualdad de caudal son proporcionales a la densidad.

$$\Delta pt_2 = \Delta pt_1 \frac{\gamma_2}{\gamma_1} \quad P_{A2} = P_{A1} \frac{\gamma_2}{\gamma_1}$$

### Ejemplos de selección utilizando las Tablas de Selección Rápida.

**1.- Aire en condiciones normales** (Altitud sobre el nivel del mar: 0 m, Temperatura del aire: 20°C). (Estos valores son los de las tablas de selección).

**2.- Aire en condiciones especiales** (Altitud sobre el nivel del mar: 750 m, Temperatura del aire 38°C).

- Caudal de aire: 3.900 m<sup>3</sup>/h.

- Presión estática: 500 Pa.

- Corrección de la presión estática según tabla 1: 500 / 0,863 = 579,4 Pa.

- Caja seleccionada: TBS-12/6, Pe motor: 1,5 kW, n=1350 min<sup>-1</sup> (las revoluciones reales del ventilador son las leídas en la tabla, la potencia eléctrica del motor sería de 1,5 kW (leída en la tabla) x 0,863 = 1,29 kW, manteniéndose en este caso 1,5 kW).

TABLA N° 1

TEMPERATURA DEL AIRE °C	ELEVACION SOBRE EL NIVEL DEL MAR (m)									
	Nivel del mar	300	450	600	750	900	1200	1500	1800	2100
	PRESION BAROMETRICA mm Hg									
	760	735	720	705	695	680	655	630	610	585
-40	1,234	1,191	1,170	1,150	1,128	1,105	1,066	1,028	0,987	0,956
-18	1,152	1,110	1,092	1,072	1,052	1,033	0,950	0,957	0,922	0,894
0	1,082	1,043	1,024	1,005	0,990	0,970	0,934	0,900	0,865	0,838
20	1,000	0,964	0,947	0,930	0,913	0,896	0,864	0,832	0,799	0,774
38	0,946	0,912	0,895	0,878	0,863	0,847	0,816	0,785	0,755	0,732
66	0,869	0,838	0,824	0,807	0,793	0,779	0,750	0,722	0,695	0,672
93	0,803	0,775	0,760	0,747	0,733	0,720	0,693	0,667	0,642	0,622
121	0,747	0,720	0,707	0,695	0,682	0,670	0,645	0,622	0,592	0,578
149	0,679	0,672	0,660	0,647	0,626	0,625	0,602	0,579	0,577	0,540
177	0,654	0,630	0,620	0,608	0,597	0,586	0,564	0,543	0,522	0,507
205	0,616	0,594	0,583	0,572	0,562	0,552	0,532	0,512	0,482	0,477



## **difusión - acústica - cortafuegos ventilación**



Tel:+34 91 692 72 40 · Fax:+34 91 692 72 41

Airsum, s.l. · CL. Alcotanes, 17 · E-28320 Pinto Madrid

[airsum@airsum.es](mailto:airsum@airsum.es) · [www.airsum.es](http://www.airsum.es) · [www.tecnigrupo.es](http://www.tecnigrupo.es)

