

## CAJAS DE VENTILACION “CEB”(Certified Exhaust Box)

*Caisson de Ventilation “CEB”*

VENTILATION MOTOR BOX “CEB”

*Unidades de Ventilação “CEB”*

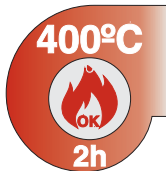

Homologadas  
Según Norma UNE  
EN-12101-3:2002

### GENERALIDADES

Las cajas de ventilación "**CEB**" (Certified Exhaust Box), previstas para un doble uso, extracción de aire convencional y de emergencia con aire a 400°C durante 2h para trabajar en el exterior de la zona de riesgo. Fabricadas en chapa de acero galvanizada Z-275. Están **homologadas según norma UNE EN-12101-3:2002** en Laboratorio Certificado de Resistencia al Fuego y con certificación **CE**.

Contienen en su interior un ventilador centrífugo, de doble aspiración con rodete de álabes insertos, tipo acción, equilibrado estática y dinámicamente, con máquinas electrónicas de alta sensibilidad según norma VDI-2060 y grado de equilibrado Q=6.3. El ventilador está accionado mediante transmisión por correas y poleas por un motor montaje B3 situado en el interior.



El eje, fabricado en acero F-114 calibrado h8, va montado sobre dos rodamientos a bolas autoalineables con soporte de fundición y situados fuera de la corriente de aire de extracción.

El motor queda incorporado dentro de la caja sobre un soporte motor deslizante para facilitar de forma sencilla y precisa el sistema de tensionado y alineación de la transmisión. El motor queda fuera de la corriente de aire.

La caja se fabrica normalmente con descarga Horizontal (H), con el motor a la derecha visto desde la boca de impulsión. Bajo demanda se pueden montar con el motor situado a la izquierda visto desde la boca de impulsión y con descarga Vertical (V); y con el motor tanto a derechas como a izquierdas.

### MOTORES

Según la directiva 2005/32/CE. "A partir del 1 de enero de 2017: los motores con una potencia nominal de 0,75-375 kW no podrán tener un nivel de rendimiento inferior al nivel de rendimiento IE3, definido en el anexo I, punto 1, o al nivel IE2, definido en el anexo I, punto 1, y estar equipados de un mando de regulación de velocidad".

Los motores son de eficiencia IE2/IE3 (Protección IP-55) según norma Europea IEC, con aislamiento clase F, montaje B3, cojinetes con rodamientos a bolas y protector térmico incorporado.

Los motores son trifásicos, para tensión de 230/400V - 50 Hz (hasta 4,0 kW) y 400/690V - 50 Hz (para potencias mayores de 4,0 kW).

Los motores instalados abarcan potencias desde 0,25 kW a 15,0 kW según los distintos tamaños de las cajas.

### MONTAJE

Cada unidad va provista de cuatro escuadras para su montaje indistintamente tanto apoyada como colgada.

### APLICACIONES

Las cajas de ventilación "**CEB**" cumplen la norma UNE-EN 12101-3:2002 para la evacuación de humos (desenfumage) en caso de incendios, por ejemplo en garajes, extracción de cocinas, etc.

### GAMA

La gama comprende 9 cajas y abarca desde el tamaño de ventilador 9/9 (2.000 m³/h) hasta el tamaño 30/28 (50.000 m³/h) y con presiones estáticas hasta unos 700 Pa.

### ACCESORIOS OPCIONALES (Bajo demanda)

- Techo para intemperie. (En construcción H).
- Visera de impulsión con malla antipájaros.
- Motores de 2 velocidades.
- Regulador de velocidad trifásico (convertidor) para regulación por frecuencia.
- Interruptor de seguridad paro-marcha.
- Conexiones flexibles especiales. (Aspiración e Impulsión).
- Soportes antivibratorios.

## RECOMENDACIONES

Atendiendo al criterio de nivel sonoro, según la aplicación de la caja, se recomienda seleccionar las cajas con las siguientes velocidades de impulsión:

- **Silenciosa:** velocidad de salida del aire de 9 a 10m/s (valor C de la curva) (instalaciones de ventilación donde el nivel sonoro deba ser mínimo, por ejemplo, viviendas, salas de conferencias, cines, hospitales, etc.).
- **Estándar:** velocidad de salida del aire de 10 a 14 m/s (valor C de la curva) (instalaciones de ventilación normal sin ningún requerimiento especial, por ejemplo, oficinas, centros comerciales, restaurantes, etc.).
- **Industrial:** velocidad de salida del aire de 14 a 16 m/s (valor C de la curva) (instalaciones de ventilación donde el nivel sonoro no necesita ser especialmente bajo o es superior al que generan las propias cajas, por ejemplo, aparcamientos, cocinas industriales, etc.).

La selección de una caja de ventilación consiste en determinar el tamaño de caja adecuado, potencia del motor y revoluciones del ventilador para las condiciones de caudal y presión requeridas, teniendo en cuenta las siguientes consideraciones:

- **Criterios económicos,** intentar seleccionar la caja con el mayor rendimiento posible ya que a mayor rendimiento seleccionado menor consumo eléctrico y menor coste económico a largo plazo.
- **Espacio disponible,** se adjunta croquis en cada curva con las dimensiones generales de la caja.
- **Nivel sonoro** en el caso de que sea un criterio a tener en cuenta debido a la aplicación en la que es utilizada la caja (Silencioso, Estándar, Industrial).

## EJEMPLO DE SELECCIÓN CAJAS DE VENTILACIÓN "CEB" 400°C/2h (Certified Exhaust Box)

Las condiciones de trabajo deseadas son:

- Caudal de 9.500 m<sup>3</sup>/h.
- Pérdida de carga estática a vencer de la red de conductos de 36 mm.c.d.a (353 Pa).

Para las condiciones dadas, podríamos seleccionar dos cajas (ver gráfica página 4):

CEB-18/40 (18/18) con motor de 2,2 kW – mayor rendimiento (62,5%), menor consumo eléctrico, mayor tamaño y mayor coste.

CEB-15/15 (15/15) con motor de 3,0 kW – menor rendimiento (57%), mayor consumo eléctrico, menor tamaño y menor coste.

Dependiendo de la instalación, aplicación de la caja e importe de la misma, se decidiría cual de las dos variantes es la más apropiada.

## TABLAS DE CONVERSION

PRESION								CAUDAL DE AIRE							
	Pa	mbar	bar	kg/cm <sup>2</sup>	mm.c.d.a.	mm Hg	psi		m <sup>3</sup> /h	m <sup>3</sup> /seg	l/h	l/seg	SCFM	SCFH	SCIM
1 Pa	1	0.01	1x10 <sup>-5</sup>	102x10 <sup>-7</sup>	0.102	0.0075	145x10 <sup>-6</sup>	1 m <sup>3</sup> /h	1	2.67x10 <sup>-4</sup>	1,000	0.267	0.59	35.34	1022.5
1 mbar	100	1	0.001	102x10 <sup>-5</sup>	10.2	0.750	0.0145	1 m <sup>3</sup> /seg	3600	2.67x10 <sup>-4</sup>	3.6x10 <sup>6</sup>	1000	2,120	1.27x10 <sup>5</sup>	3.68x10 <sup>6</sup>
1 bar	100,000	1,000	1	1.02	10,200	750	14.5038	1 l/h	0.001	2.67x10 <sup>-7</sup>	1	2.67x10 <sup>-4</sup>	5.9x10 <sup>-4</sup>	35.34x10 <sup>-3</sup>	1.02
1 Kg/cm <sup>2</sup>	98,100	981	0.981	1	10,000	736	14.2233	1 l/seg	3.6	0.001	3600	1	2.12	127.2	3,670.2
1 mm c.d.a.	9.81	0.098	9.81x10 <sup>-6</sup>	0.0001	1	0.0736	0.001422	1 SCFM	1.695	4.72x10 <sup>-4</sup>	1,695	0.472	1	60	1,728
1 mm Hg	133.3	1.33	0.00133	0.001359	13.59	1	0.01934	1 SCIM	0.98x10 <sup>-3</sup>	2.72x10 <sup>-7</sup>	0.98	2.72x10 <sup>-4</sup>	0.00058	0.0347	1
1 psi	6,895.06	68.95	0.06895	0.07031	703.1	51.717	1	1 SCFH	0.0283	7.87x10 <sup>-6</sup>	28.30	7.87x10 <sup>-3</sup>	0.0167	1	28.8

POTENCIA								
	W	kW	kgm/s	ch	Hp	kcal/h	BTU/min	BTU/hr
1 W	1	0.001	0.102	1.359x10 <sup>-3</sup>	1.341x10 <sup>-3</sup>	0.860	0.0568	3.41
1 kW	1,000	1	101.97	1.359	1.341	860	56.85	3,413
1 kgm/s	9.81	9.81x10 <sup>-3</sup>	1	0.0133	0.0131	8.424	0.5568	3.34
1 ch	736	0.736	75	1	0.98632	633.6	41.881	2,513
1 Hp	746	0.746	76	1.01387	1	642.4	42.462	2,544
1 kcal/h	1.163	1.163x10 <sup>-3</sup>	0.119	0.00158	0.00156	1	0.0661	3.97
1 BTU/min	17.606	0.0176	1.796	0.0239	0.02355	15.3	1	62.5
1 BTU/hr	0.293	0.293x10 <sup>-3</sup>	0.299	0.398x10 <sup>-3</sup>	0.393x10 <sup>-3</sup>	0.252	0.016	1

### Cálculo del Punto de Trabajo, Revoluciones del Ventilador y Selección del Motor

#### CEB-18/40 (18/18) motor 2,2 kW

- Caudal (Q) = 9.500 m<sup>3</sup>/h
- Presión estática (Pe) = 36 mm.c.d.a. (353 Pa)
- Presión dinámica (Pd) = 6 mm.c.d.a. (59 Pa)
- Presión total (Pt) = 42 mm.c.d.a. (412 Pa)
- Rendimiento (η) = 62,5%
- Revoluciones del ventilador (n) = 710 min<sup>-1</sup>
- Potencia motor (Pe) = 2,2 kW
- Velocidad de impulsión (C) = 9,9 m/s

#### CEB-15/15 (15/15) motor 3,0 kW

- Caudal (Q) = 9.500 m<sup>3</sup>/h
- Presión estática (Pe) = 36 mm.c.d.a. (353 Pa)
- Presión dinámica (Pd) = 11 mm.c.d.a. (108 Pa)
- Presión total (Pt) = 47 mm.c.d.a. (461 Pa)
- Rendimiento (η) = 57%
- Revoluciones del ventilador (n) = 860 min<sup>-1</sup>
- Potencia motor (Pe) = 3,0 kW
- Velocidad de impulsión (C) = 13,3 m/s

### Ejemplo de pedido:

Caja seleccionada: CEB-15/15 (15/15)-H-3-D

Modelo	Tamaño	Descarga	Motor kW	Montaje Motor	Accesorios	Caudal m <sup>3</sup> /h	Presión Estática Pa ó mm.c.d.a.
CEB	15/15 (15/15)	H	3.0	Derecha	---	9,500	36 mm.c.d.a.

Caja de ventilación "CEB" 400°C/2h 15/15 (15/15)-H-3-D, homologada según Norma UNE-EN-12101-3:2002 Tamaño 15/15 - Descarga Horizontal - Motor 3 kW 4 Polos 50 Hz.IE2 (montado a derecha). Para un caudal de 9.500 m<sup>3</sup>/h y 36 mm.c.d.a de presión estática.

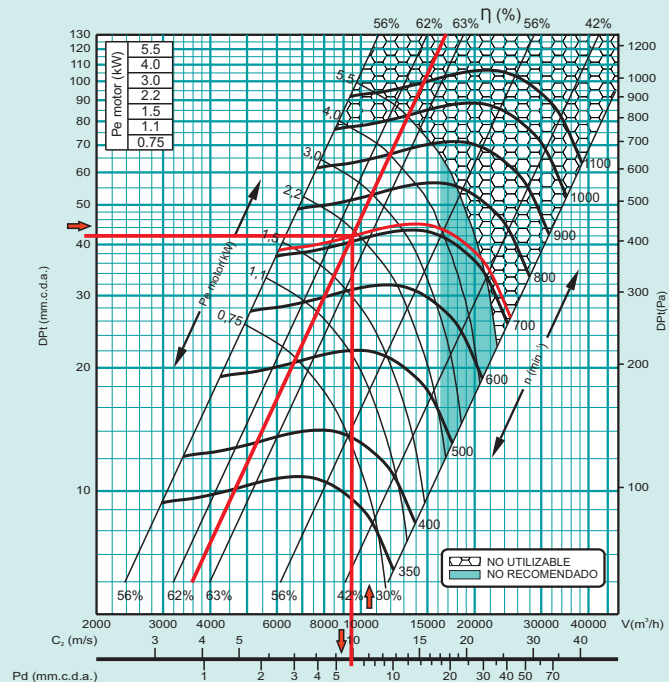
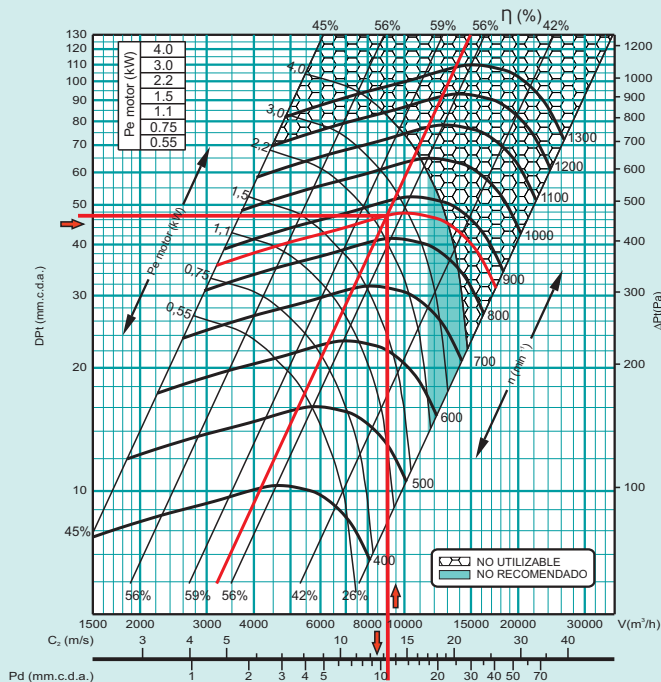

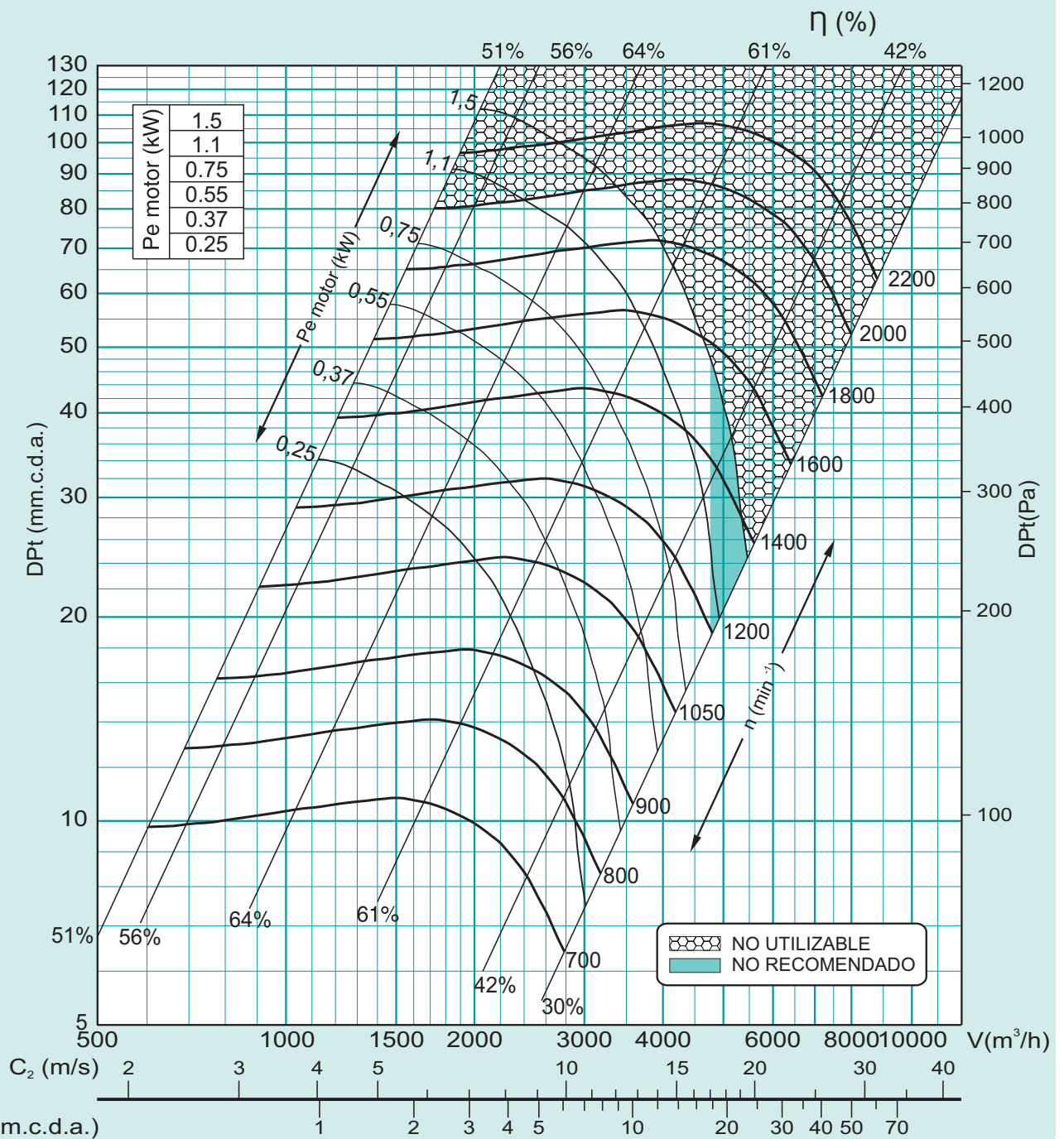
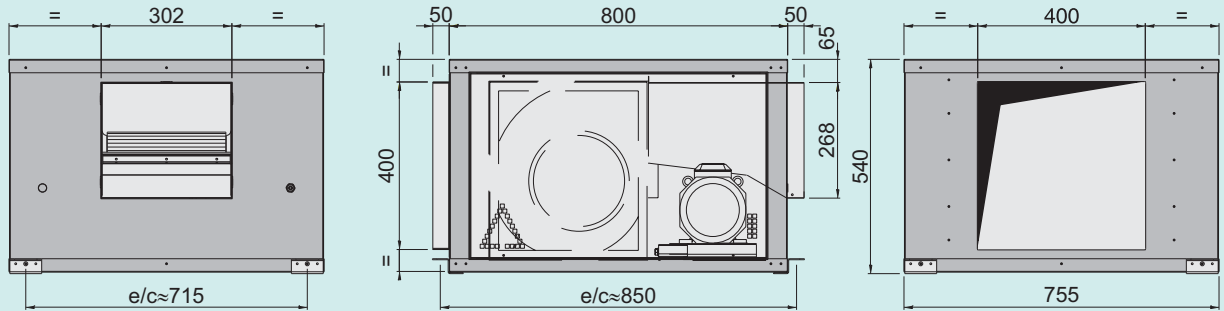

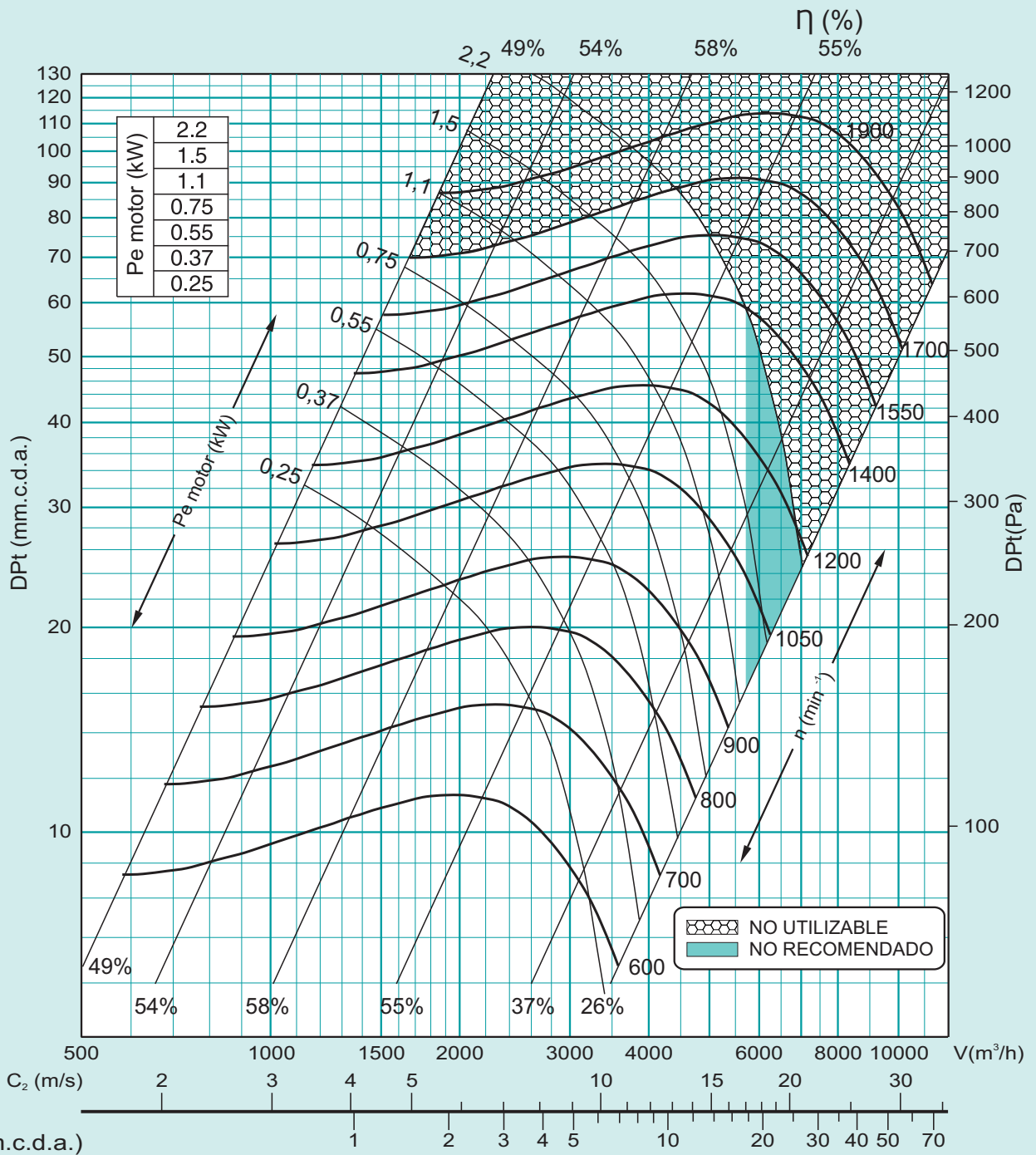
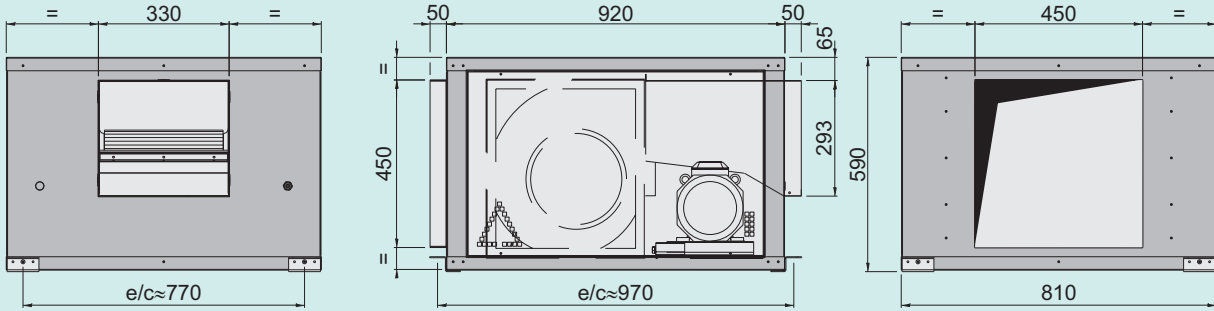

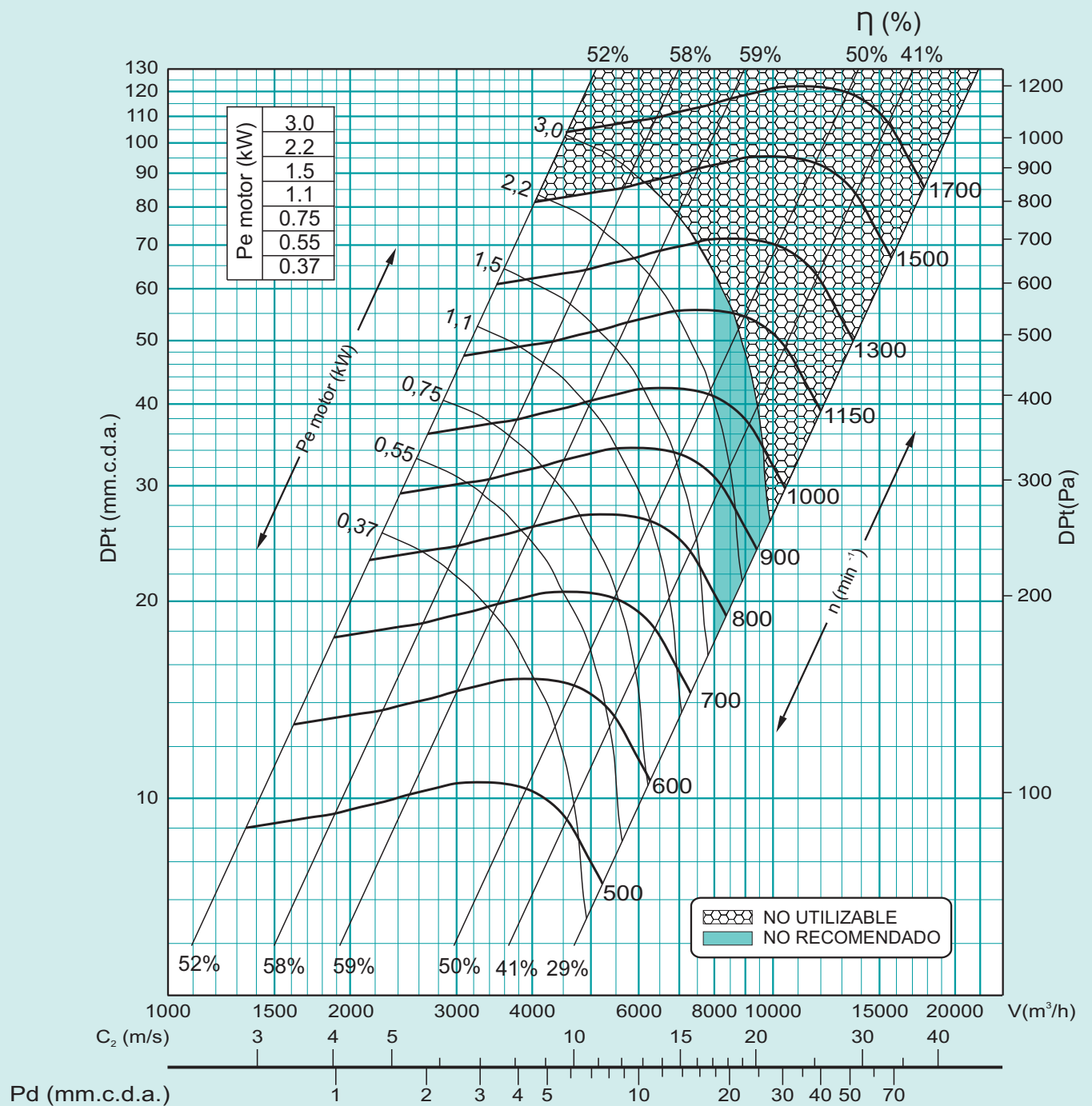
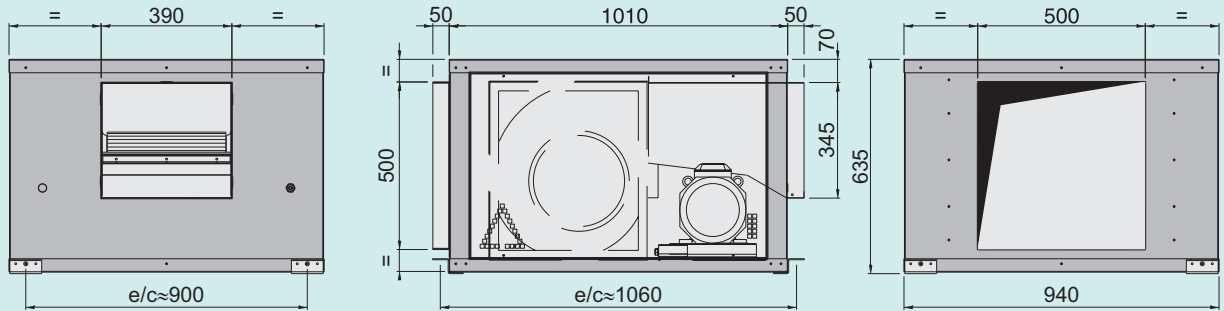

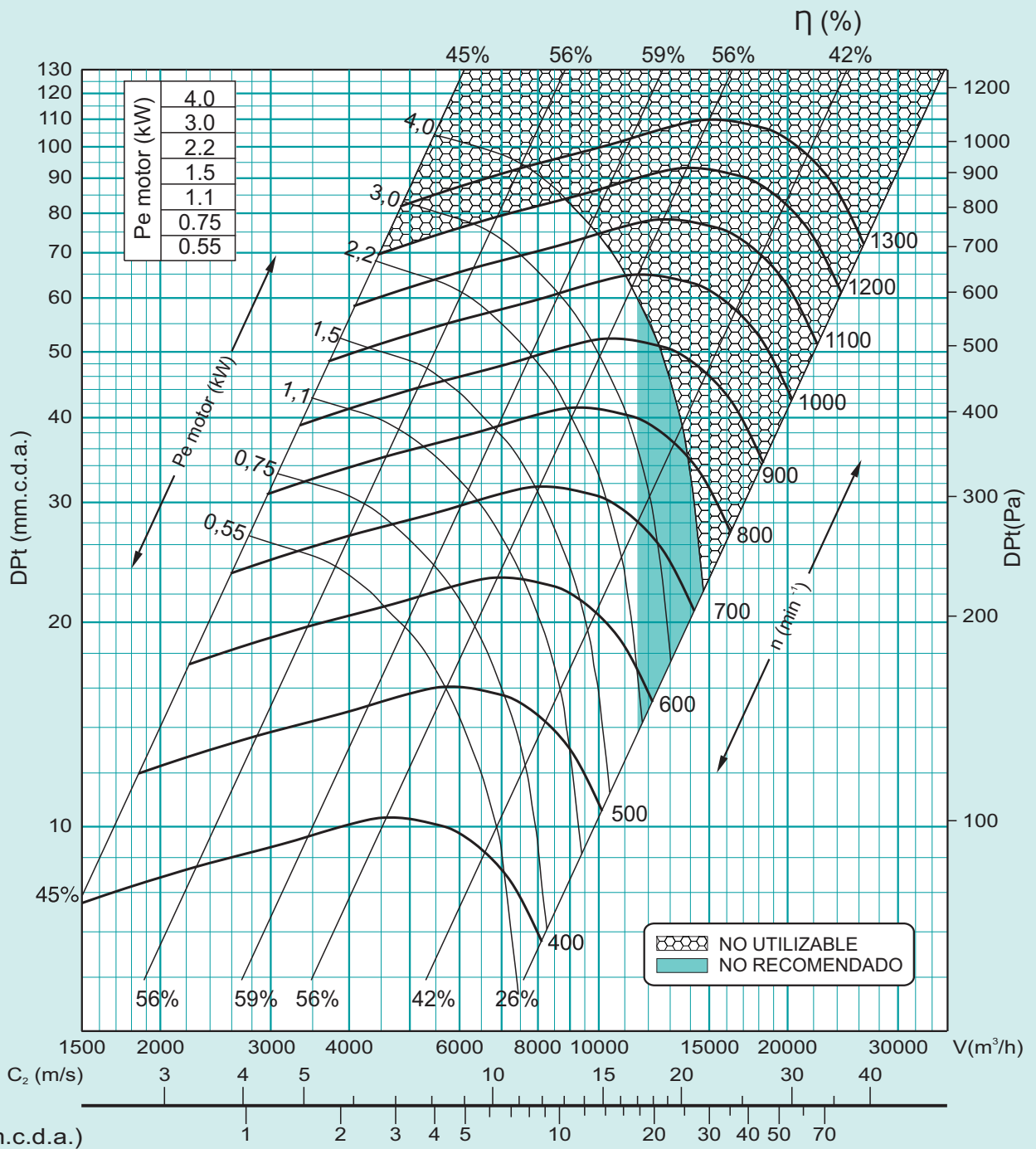
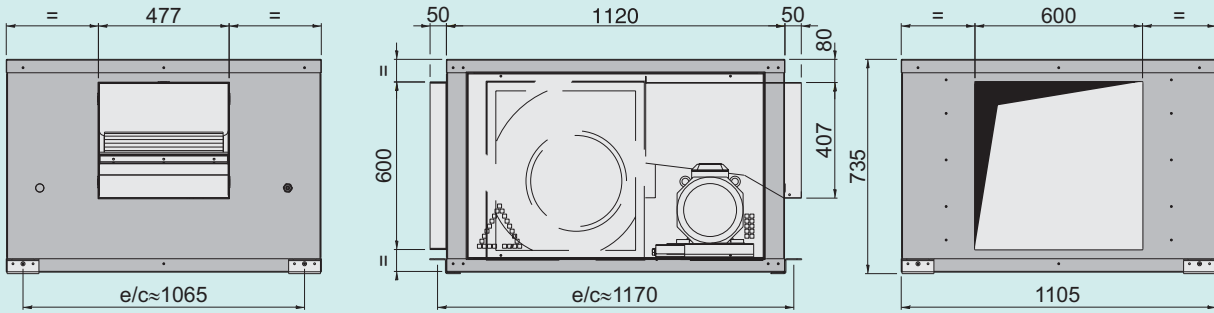

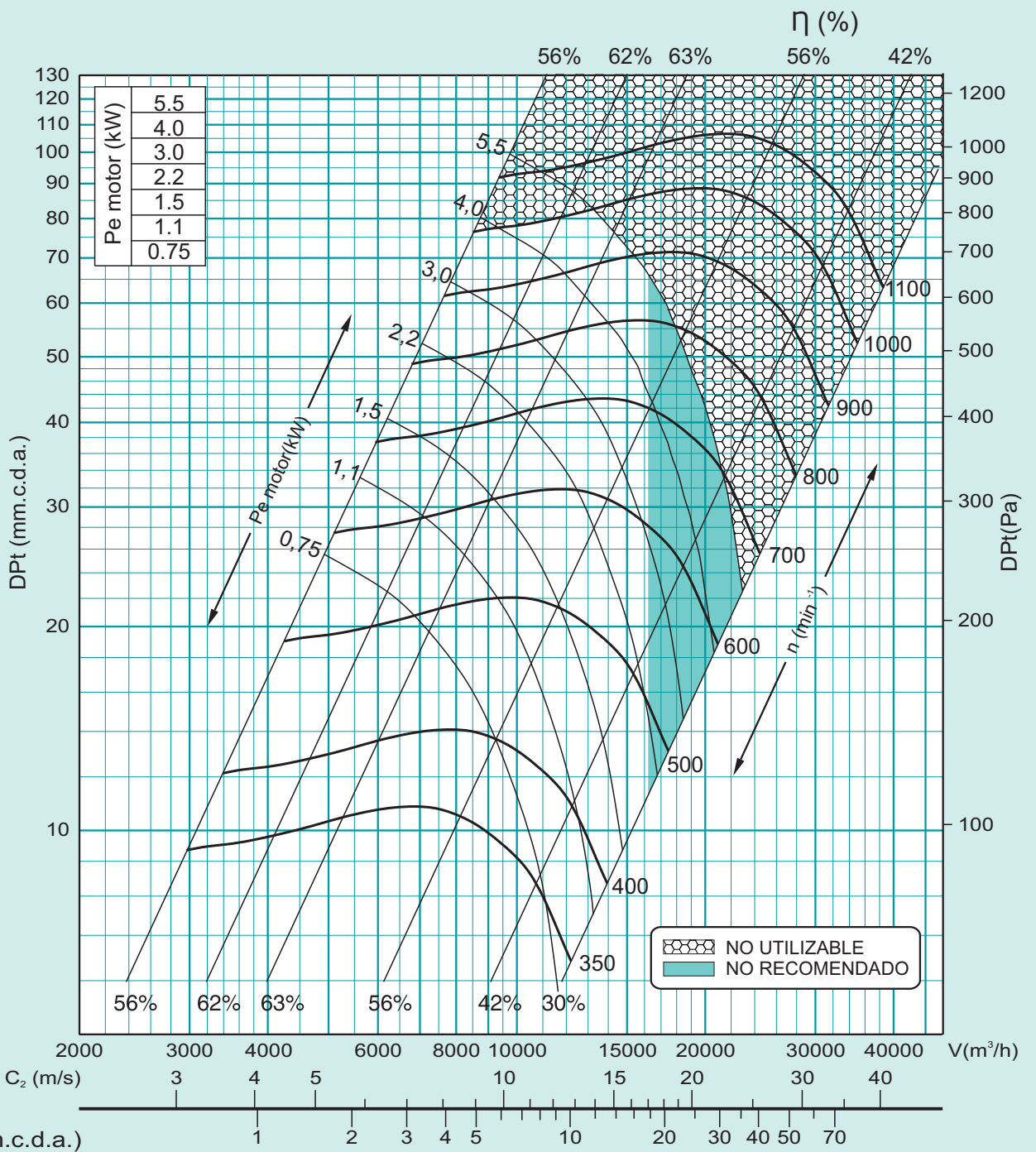
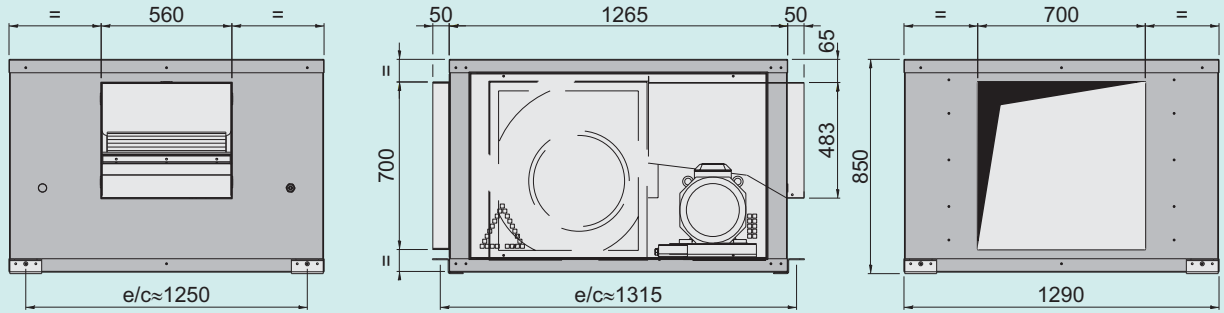

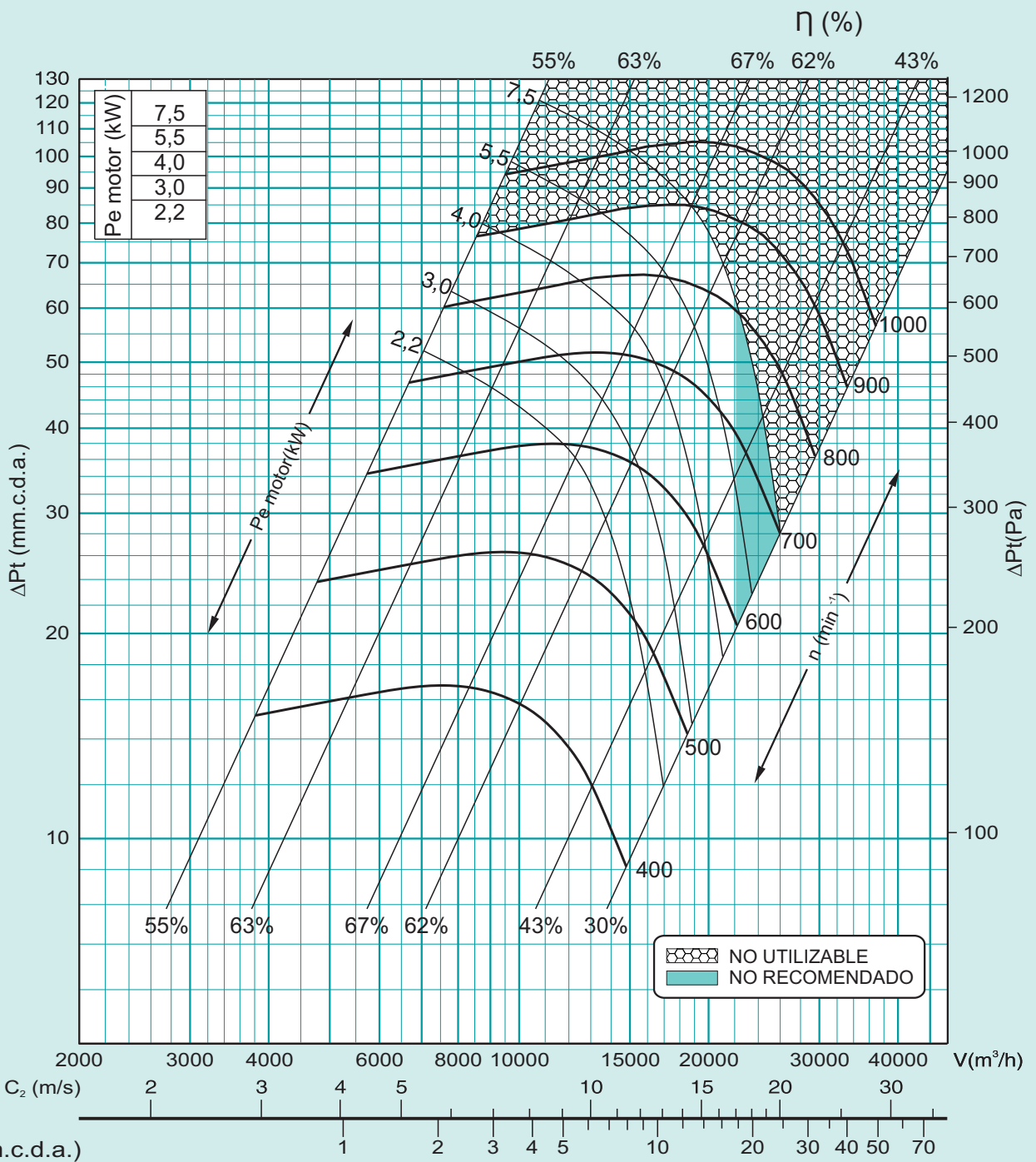
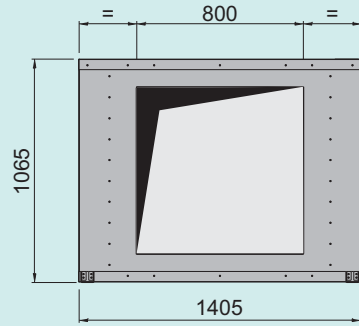
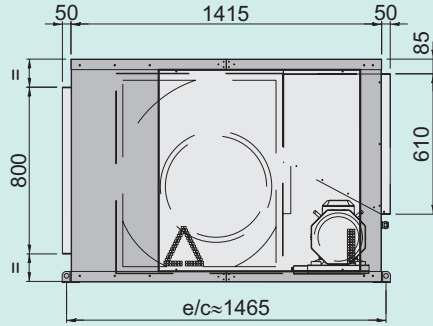
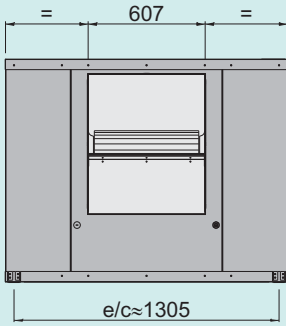

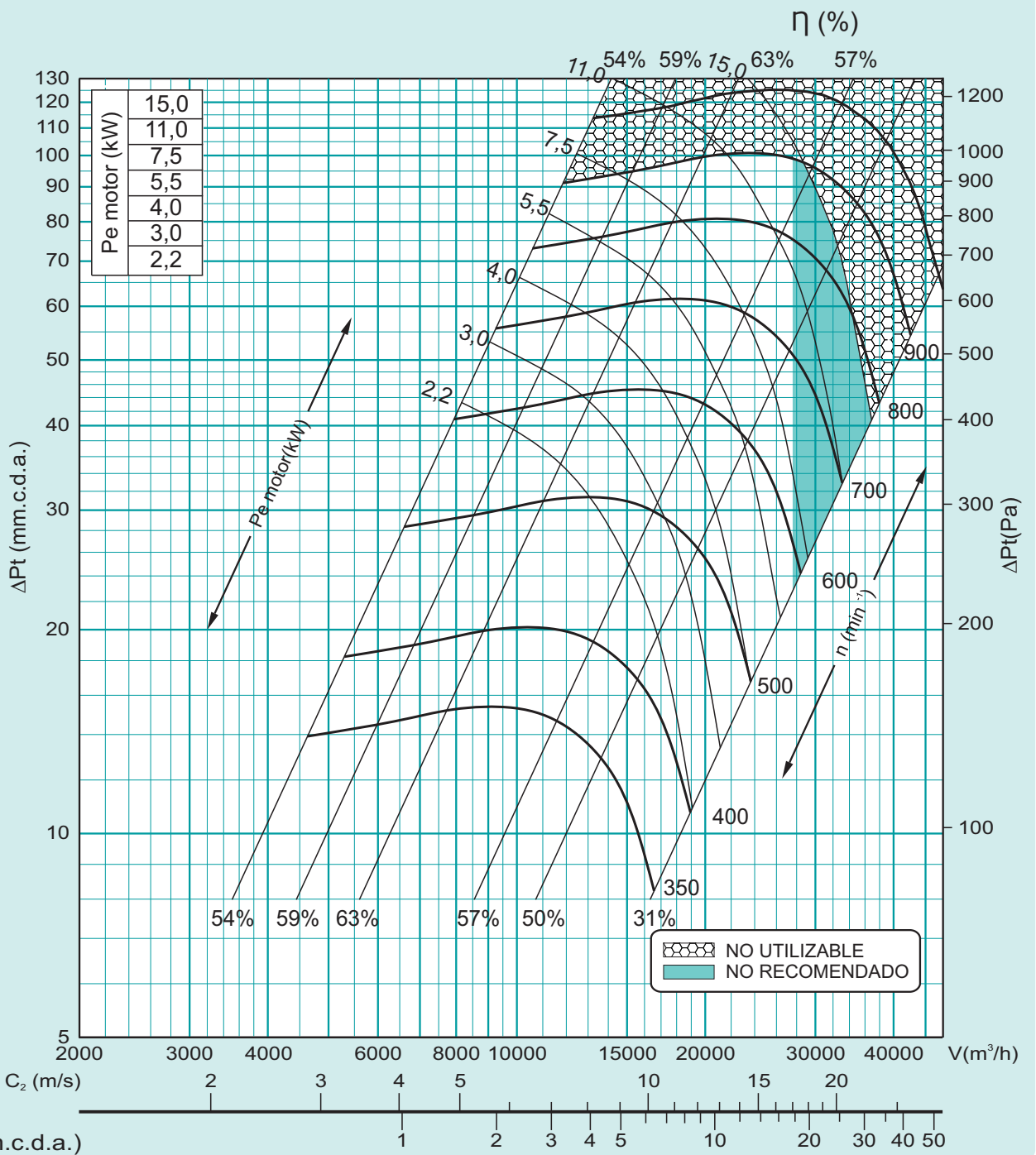
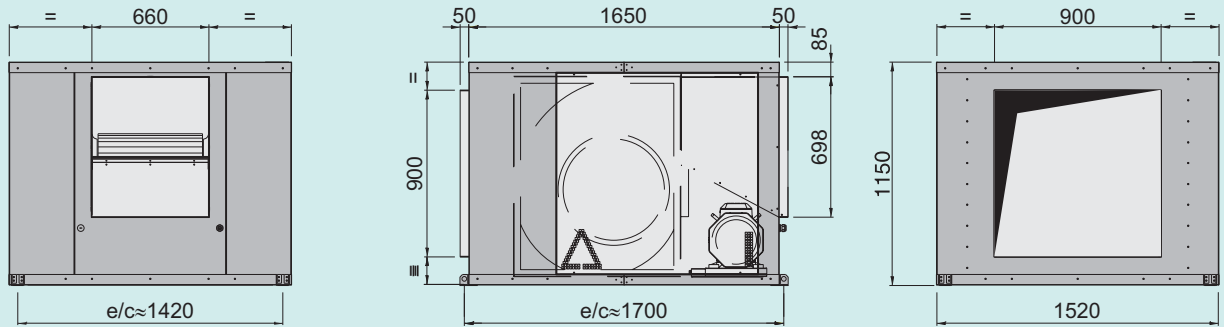

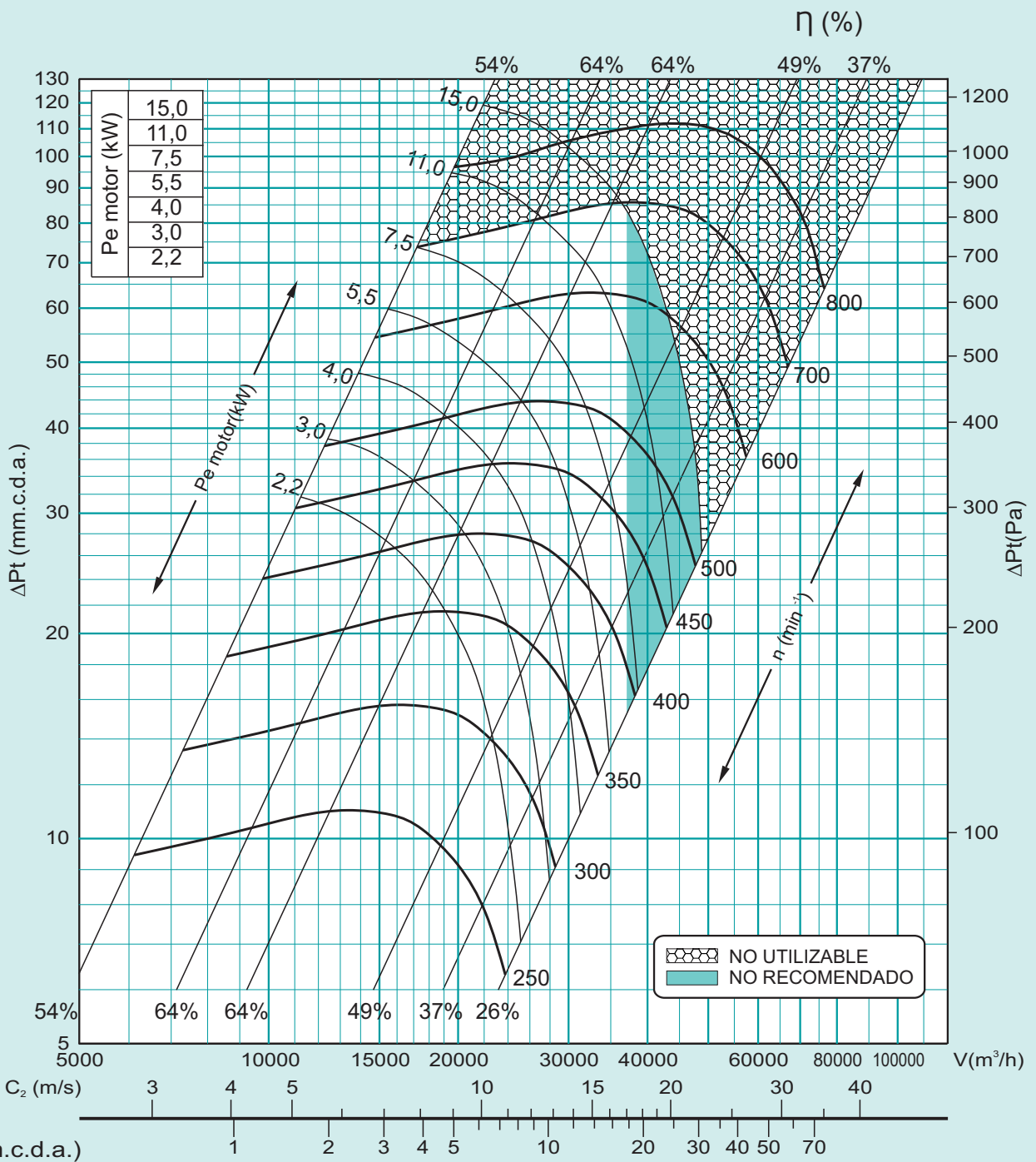
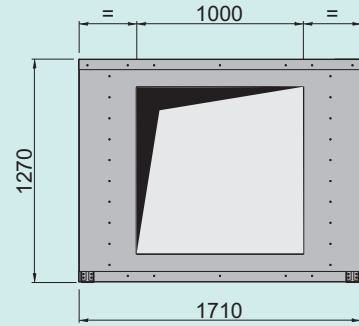
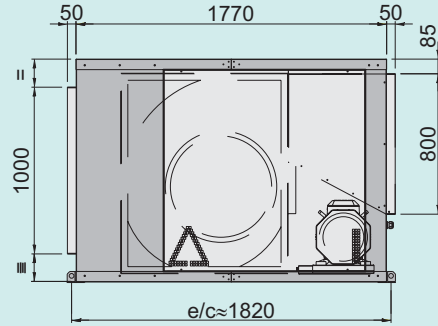
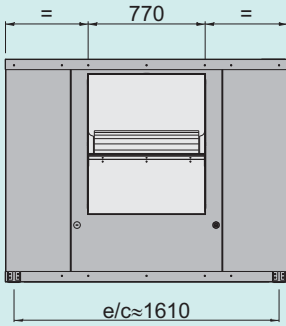

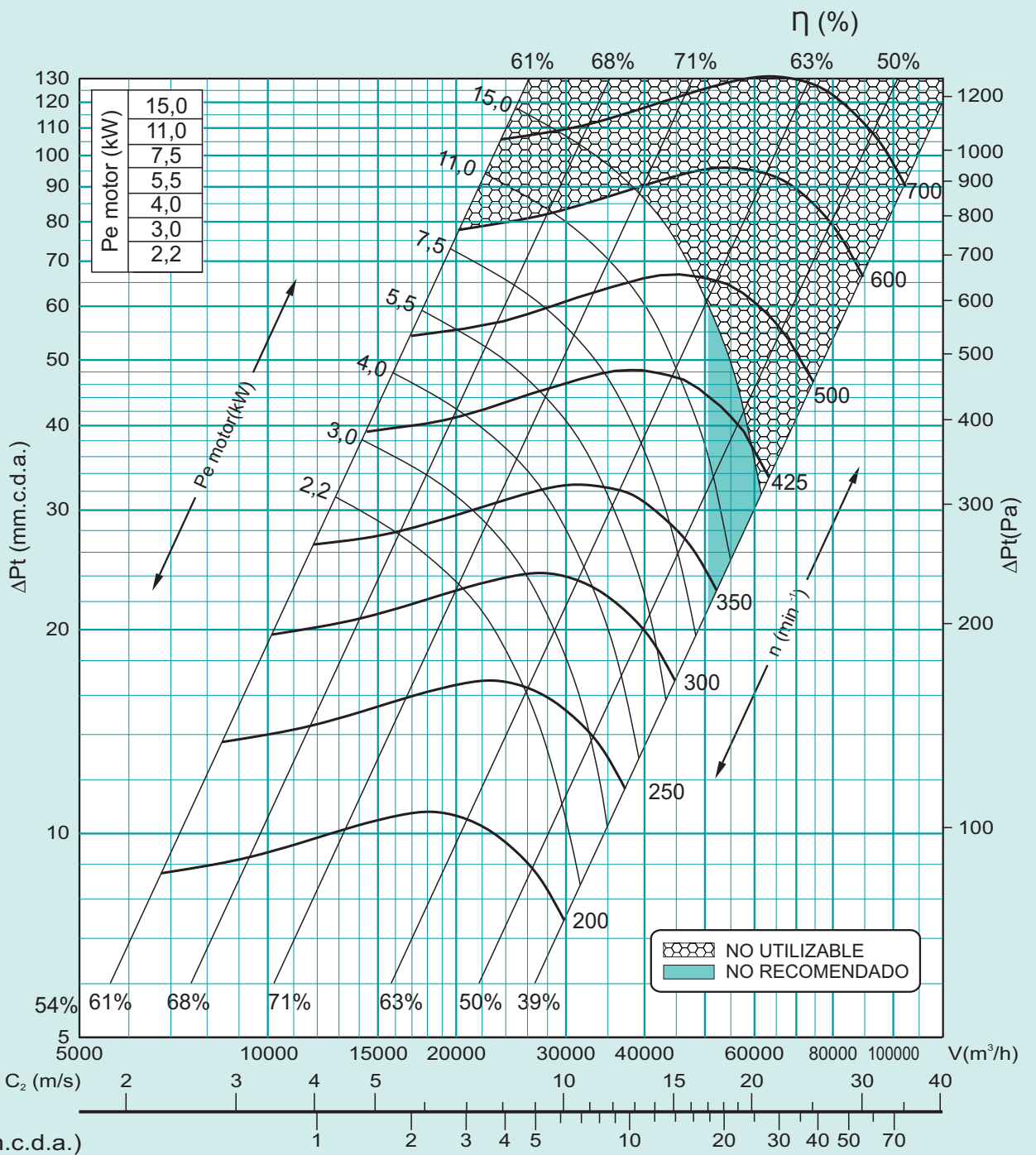
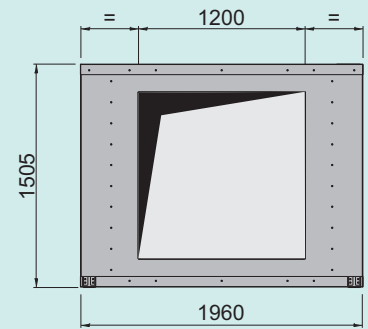
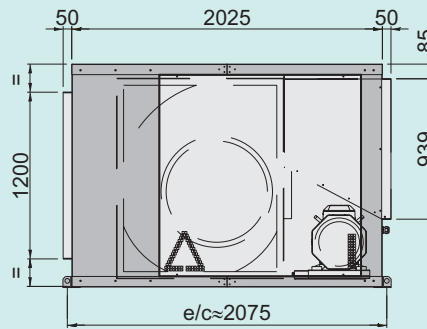
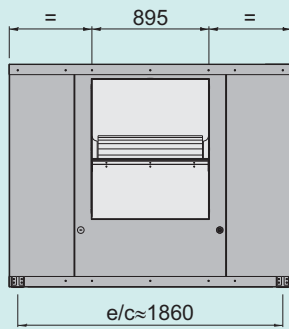

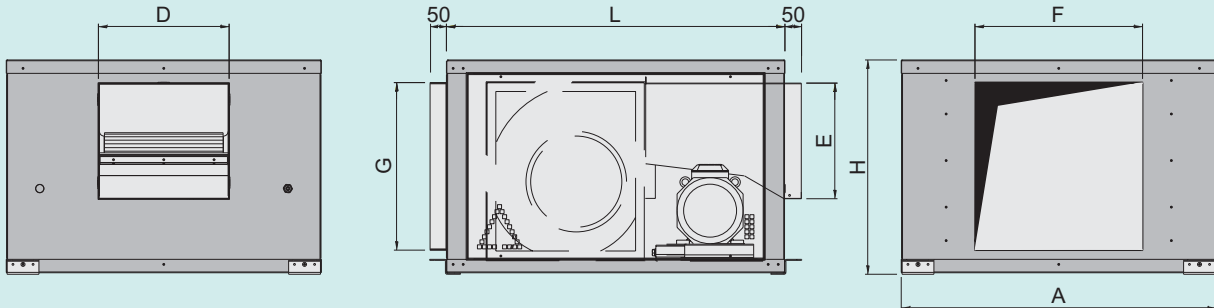

Modelo y Tamaño	Dimensiones Generales y Peso							
	Dimensiones (mm)			Boca Impulsión (mm)		Boca Aspiración (mm)		Peso aprox <sup>(1)</sup> (Kg)
	A	H	L	D	E	F	G	
CEB-9/22	755	540	800	302	268	400	400	74
CEB-10/10	810	590	920	330	293	450	450	86
CEB-12/28	940	635	1010	390	345	500	500	111
CEB-15/15	1105	735	1120	477	407	600	600	149
CEB-18/40	1290	850	1265	560	483	700	700	192
CEB-20/20	1405	1065	1415	607	610	800	800	305
CEB-22/22	1520	1150	1650	660	698	900	900	355
CEB-25/25	1710	1270	1770	770	800	1000	1000	424
CEB-30/71	1960	1505	2025	895	939	1200	1200	543

(1) Pesos aproximados sin motor (ver pesos de motores en las tablas de características de la gama de motores).

Modelo y Tamaño	Ventilador (Pulgadas)	Peso aproximado en (Kg) Gama de Motores Potencia kW												
		0,25	0,37	0,55	0,75	1,1	1,5	2,2	3,0	4,0	5,5	7,5	11,0	15,0
CEB-9/22	9/9	(83)	(84)	(86)	(91)	(95)	(100)							
CEB-10/10	10/10	(95)	(96)	(98)	(103)	(107)	(112)	(120)						
CEB-12/28	12/12		(121)	(123)	(128)	(132)	(137)	(145)	(149)					
CEB-15/15	15/15			(161)	(166)	(170)	(175)	(183)	(187)	(197)				
CEB-18/40	18/18				(208)	(212)	(217)	(225)	(229)	(239)	(256)			
CEB-20/20	20/20							(339)	(343)	(353)	(370)	(386)		
CEB-22/22	22/22							(389)	(393)	(403)	(420)	(436)	(495)	(518)
CEB-25/25	25/25							(458)	(462)	(472)	(489)	(505)	(564)	(587)
CEB-30/71	30/28							(577)	(581)	(591)	(608)	(624)	(683)	(706)

( ) Gama de fabricación y pesos aproximados cajas CEB con motor IE3 en Kg.

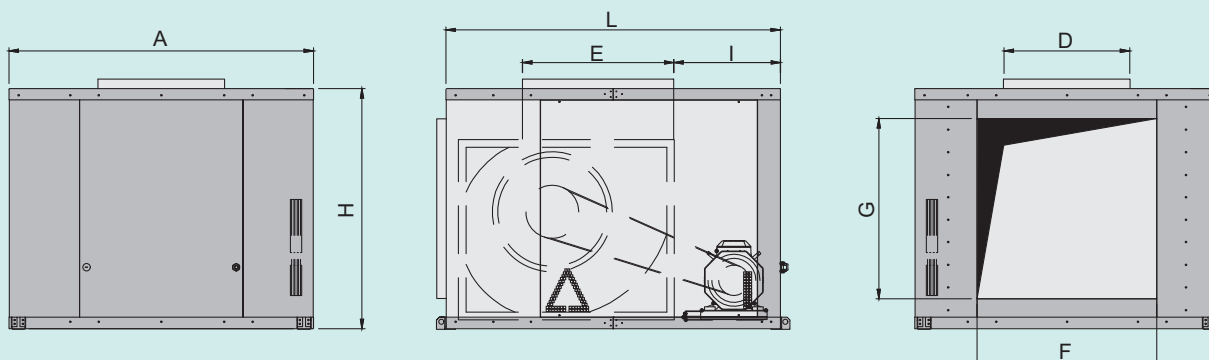

Modelo y Tamaño	Dimensiones Generales y Peso							
	Dimensiones (mm)			Boca Impulsión (mm)		Boca Aspiración (mm)		
	A	H	L	D	E	F	G	I
CEB-9/22-V	755	540	825	302	268	400	400	370
CEB-10/10-V	810	590	935	330	293	450	450	428,5
CEB-12/28-V	940	635	1010	390	345	500	500	421
CEB-15/15-V	1105	735	1120	477	407	600	600	421
CEB-18/40-V	1290	850	1265	560	483	700	700	421
CEB-20/20-V	1405	1065	1415	607	610	800	800	439
CEB-22/22-V	1520	1150	1650	660	698	900	900	565
CEB-25/25-V	1710	1270	1770	770	800	1000	1000	565
CEB-30/71-V	1960	1505	2025	895	939	1200	1200	565

(1) Pesos aproximados sin motor (ver pesos de motores en las tablas de características de la gama de motores).

Modelo y Tamaño	Ventilador (Pulgadas)	Peso aproximado en (Kg) Gama de Motores Potencia kW												
		0,25	0,37	0,55	0,75	1,1	1,5	2,2	3,0	4,0	5,5	7,5	11,0	15,0
CEB-9/22	9/9	(83)	(84)	(86)	(91)	(95)	(100)							
CEB-10/10	10/10	(95)	(96)	(98)	(103)	(107)	(112)	(120)						
CEB-12/28	12/12		(121)	(123)	(128)	(132)	(137)	(145)	(149)					
CEB-15/15	15/15			(161)	(166)	(170)	(175)	(183)	(187)	(197)				
CEB-18/40	18/18				(208)	(212)	(217)	(225)	(229)	(239)	(256)			
CEB-20/20	20/20							(339)	(343)	(353)	(370)	(386)		
CEB-22/22	22/22							(389)	(393)	(403)	(420)	(436)	(495)	(518)
CEB-25/25	25/25							(458)	(462)	(472)	(489)	(505)	(564)	(587)
CEB-30/71	30/28							(577)	(581)	(591)	(608)	(624)	(683)	(706)

( ) Gama de fabricación y pesos aproximados cajas CEB con motor IE3 en Kg.

GAMA MOTORES 4 POLOS 50 Hz IE3									
Potencia (kW)	Carcasa	Velocidad Nominal (min <sup>-1</sup> )	Intensidad						Peso (Kg)
			Nominal (A)			Arranque (A)			
			230 V	400 V	690 V	230 V	400 V	690 V	
0,25	71M	1400	1,4	0,8	---	8,7	5,0	---	5
0,37	71M	1400	1,8	1,0	---	11,6	6,7	---	6
0,55	80M	1420	2,6	1,5	---	11,6	6,7	---	8
0,75	80M	1430	3,3	1,9	---	20,5	11,8	---	12
1,1	90S	1440	4,6	2,6	---	32,4	18,7	---	15
1,5	90L	1440	6,2	3,6	---	44,2	25,6	---	18
2,2	100L	1450	7,8	4,5	---	61,5	35,6	---	24
3,0	100L	1450	11,0	6,4	---	89,3	51,6	---	28
4,0	112M	1450	---	8,0	4,6	---	68,8	39,7	34
5,5	132S	1460	---	10,6	6,1	---	95,4	55,2	47
7,5	132M	1460	---	14,1	8,2	---	125,5	72,5	58
11,0	160M	1440	---	19,1	11,0	---	190,9	110,3	126
15,0	160L	1445	---	25,6	14,8	---	217,2	125,5	149

Nota: Estos valores pueden variar ligeramente en función del fabricante del motor.

GAMA MOTORES 6 POLOS 50 Hz IE3									
Potencia (kW)	Carcasa	Velocidad Nominal (min <sup>-1</sup> )	Intensidad						Peso (Kg)
			Nominal (A)			Arranque (A)			
			230 V	400 V	690 V	230 V	400 V	690 V	
4,0	132M	970	---	9,0	5,2	---	61,2	35,4	48
5,5	132M	970	---	12,1	7,0	---	89,5	51,7	55
7,5	160M	955	---	25,2	14,6	---	188,9	109,1	110
11,0	160L	960	---	20,7	12,0	---	176,0	101,7	142
15,0	180L	960	---	28,6	16,5	---	228,8	132,2	179

Nota: Estos valores pueden variar ligeramente en función del fabricante del motor.

GAMA MOTORES 2 VELOCIDADES 4/8 POLOS 50 Hz							
Potencia 4P/8P (kW)	Carcasa	Velocidad Nominal (min <sup>-1</sup> )	Intensidad 400V 50Hz				Peso (Kg)
			Nominal (A)		Arranque (A)		
			4P	8P	4P	8P	
0,25/0,03	71M	1370/710	1,2	0,5	4,20	1,40	6
0,33/0,04	71M	1360/710	1,5	0,5	6,00	1,50	6,5
0,55/0,09	80M	1410/710	2,0	1,0	9,00	3,50	9,3
0,75/0,12	80M	1430/710	1,8	0,8	12,60	3,20	10
1,1/0,18	90S	1400/710	3,0	1,5	17,40	5,40	14,3
1,5/0,25	90L	1380/700	4,0	1,5	23,20	5,40	17,2
2,2/0,37	100L	1430/720	4,0	2,0	28,00	9,00	23
3,0/0,55	100L	1420/710	6,6	2,5	45,54	10,00	25
4,0/1,0	112M	1440/720	8,5	3,0	63,75	13,50	33
5,5/1,1	132S	1450/720	11,0	4,0	93,50	20,00	40,4
7,5/1,1	132M	1450/720	15,0	5,8	138,00	29,00	48,8
11,0/2,3	160M	1460/720	22,0	8,5	176,00	34,00	85
15,0/3,0	160M	1460/720	28,5	11,5	213,75	46,00	88

GAMA MOTORES 2 VELOCIDADES 4/6 POLOS 50 Hz									
Potencia 4P/6P (kW)	Carcasa	Velocidad Nominal (min <sup>-1</sup> )	Intensidad 400V 50Hz				Peso (Kg)		
			Nominal (A)		Arranque (A)				
			4P	6P	4P	6P			
0,25/0,09	71M	1380/950	1,3	0,5	3,90	1,25	6,4		
0,37/0,12	80M	1420/960	1,5	0,7	6,75	2,80	9,3		
0,55/0,16	80M	1420/960	1,8	0,8	8,10	3,36	10		
0,75/0,25	90S	1410/950	2,5	0,9	11,25	3,78	14,3		
1,1/0,37	90L	1410/950	3,2	1,5	14,40	6,30	16,5		
1,5/0,5	90L	1420/950	4,0	1,6	22,00	8,00	17,2		
2,2/0,75	100L	1430/950	5,0	2,4	32,50	10,32	25		
3,0/0,9	100L	1430/950	7,5	3,0	45,00	13,80	26		
4,0/1,3	132S	1440/960	9,0	4,0	70,20	22,00	40,4		
5,5/1,6	132M	1450/970	12,0	4,5	93,60	27,00	47		
7,5/2,2	132M	1450/970	15,0	6,2	120,00	34,10	49		
11,0/3,3	160M	1460/970	22,0	8,5	176,00	40,80	90		
15,0/5,0	160L	1450/970	29,0	12,5	261,00	75,00	120		

Nota: Estos valores pueden variar ligeramente en función del fabricante del motor.

Tamaño	Caudal		Vel.Imp. C <sub>2</sub> (m/s)	Pres.Din(Pd) (mm.c.d.a.)	Potencia rpm	Presión Estática Pst (mm.c.d.a.)													
	V(m³/h)	V(m³/s)				10	15	20	25	30	35	40	45	50	55	60	65	70	
<b>CEB-9/22 (9/9)</b>	2.560	0,71	9,0	4,96	Pe motor(kW)	0,25	0,37	0,37	0,55	0,55	0,55	0,75	0,75	0,75	1,1	1,1	1,1	1,1	
					n (min <sup>-1</sup> )	860	970	1070	1170	1260	1340	1420	1500	1570	1650	1720	1790	1850	
	2.840	0,79	10,0	6,10	Pe motor(kW)	0,37	0,37	0,55	0,55	0,55	0,75	0,75	0,75	1,1	1,1	1,1	1,1	1,1	1,5
					n (min <sup>-1</sup> )	910	1010	1110	1200	1280	1360	1440	1520	1590	1660	1730	1790	1860	
	3.130	0,87	11,0	7,41	Pe motor(kW)	0,37	0,55	0,55	0,75	0,75	0,75	1,1	1,1	1,1	1,1	1,1	1,5	1,5	1,5
					n (min <sup>-1</sup> )	960	1060	1150	1230	1310	1390	1460	1540	1610	1670	1740	1800	1870	
	3.410	0,95	12,0	8,80	Pe motor(kW)	0,55	0,55	0,75	0,75	1,1	1,1	1,1	1,1	1,1	1,5	1,5	1,5	1,5	1,5
					n (min <sup>-1</sup> )	1010	1100	1190	1270	1350	1420	1490	1560	1630	1700	1760	1820	1880	
3.700	1,03	13,0	10,36	Pe motor(kW)	0,55	0,75	0,75	0,75	1,1	1,1	1,1	1,1	1,5	1,5	1,5	1,5	1,5	1,5	
				n (min <sup>-1</sup> )	1070	1150	1230	1310	1380	1460	1520	1590	1660	1720	1780	1840	1900		
3.980	1,11	14,0	11,99	Pe motor(kW)	0,75	0,75	1,1	1,1	1,1	1,1	1,5	1,5	1,5	1,5	1,5	---	---	---	
				n (min <sup>-1</sup> )	1130	1200	1280	1350	1420	1490	1560	1620	1690	1750	1810	---	---		
4.260	1,18	15,0	13,73	Pe motor(kW)	0,75	1,1	1,1	1,1	1,1	1,5	1,5	1,5	---	---	---	---	---		
				n (min <sup>-1</sup> )	1180	1260	1330	1400	1470	1530	1600	1660	1720	---	---	---	---		
4.550	1,26	16,0	15,67	Pe motor(kW)	1,1	1,1	1,5	1,5	1,5	1,5	---	---	---	---	---	---	---		
				n (min <sup>-1</sup> )	1250	1310	1380	1450	1510	1580	---	---	---	---	---	---	---		

Tamaño	Caudal		Vel.Imp. C <sub>2</sub> (m/s)	Pres.Din(Pd) (mm.c.d.a.)	Potencia rpm	Presión Estática Pst (mm.c.d.a.)												
	V(m³/h)	V(m³/s)				10	15	20	25	30	35	40	45	50	55	60	65	70
<b>CEB-10/10 (10/10)</b>	3.060	0,85	9,0	4,94	Pe motor(kW)	0,37	0,55	0,55	0,55	0,75	0,75	1,1	1,1	1,1	1,1	1,5	1,5	1,5
					n (min <sup>-1</sup> )	710	800	890	970	1050	1120	1190	1260	1330	1390	1460	1520	1580
	3.400	0,94	10,0	6,10	Pe motor(kW)	0,55	0,55	0,55	0,75	0,75	1,1	1,1	1,1	1,1	1,5	1,5	1,5	1,5
					n (min <sup>-1</sup> )	750	840	920	990	1060	1130	1200	1270	1330	1390	1450	1510	1570
	3.740	1,04	11,0	7,39	Pe motor(kW)	0,55	0,55	0,75	0,75	1,1	1,1	1,1	1,1	1,5	1,5	1,5	1,5	2,2
					n (min <sup>-1</sup> )	790	870	950	1020	1090	1150	1220	1280	1340	1400	1460	1510	1570
	4.080	1,13	12,0	8,79	Pe motor(kW)	0,75	0,75	1,1	1,1	1,1	1,1	1,5	1,5	1,5	1,5	2,2	2,2	2,2
					n (min <sup>-1</sup> )	840	910	980	1050	1110	1180	1240	1300	1360	1410	1470	1520	1580
4.420	1,23	13,0	10,32	Pe motor(kW)	0,75	1,1	1,1	1,1	1,1	1,5	1,5	1,5	1,5	2,2	2,2	2,2	2,2	
				n (min <sup>-1</sup> )	880	950	1020	1080	1140	1200	1260	1320	1380	1430	1480	1540	1590	
4.760	1,32	14,0	11,96	Pe motor(kW)	1,1	1,1	1,1	1,5	1,5	1,5	1,5	2,2	2,2	2,2	2,2	2,2	2,2	
				n (min <sup>-1</sup> )	930	1000	1060	1120	1180	1230	1290	1350	1400	1450	1500	1550	1600	
5.110	1,42	15,0	13,79	Pe motor(kW)	1,1	1,5	1,5	1,5	1,5	2,2	2,2	2,2	2,2	2,2	2,2	---	---	
				n (min <sup>-1</sup> )	980	1040	1100	1160	1210	1270	1320	1370	1430	1480	1520	---	---	
5.450	1,51	16,0	15,68	Pe motor(kW)	1,5	1,5	1,5	2,2	2,2	2,2	2,2	2,2	2,2	---	---	---	---	
				n (min <sup>-1</sup> )	1030	1090	1140	1200	1250	1300	1350	1410	1450	---	---	---	---	

Tamaño	Caudal		Vel.Imp. C <sub>2</sub> (m/s)	Pres.Din(Pd) (mm.c.d.a.)	Potencia rpm	Presión Estática Pst (mm.c.d.a.)												
	V(m³/h)	V(m³/s)				10	15	20	25	30	35	40	45	50	55	60	65	70
<b>CEB-12/28 (12/12)</b>	4.280	1,19	9,0	4,96	Pe motor(kW)	0,55	0,55	0,75	0,75	1,1	1,1	1,1	1,5	1,5	1,5	2,2	2,2	2,2
					n (min <sup>-1</sup> )	590	680	770	850	920	990	1060	1130	1190	1250	1300	1360	1410
	4.750	1,32	10,0	6,11	Pe motor(kW)	0,55	0,75	0,75	1,1	1,1	1,1	1,5	1,5	1,5	2,2	2,2	2,2	2,2
					n (min <sup>-1</sup> )	620	700	780	860	930	1000	1060	1130	1190	1250	1300	1360	1410
	5.230	1,45	11,0	7,41	Pe motor(kW)	0,75	0,75	1,1	1,1	1,1	1,5	1,5	2,2	2,2	2,2	2,2	2,2	3,0
					n (min <sup>-1</sup> )	650	720	800	870	940	1010	1070	1130	1190	1250	1300	1350	1420
	5.700	1,58	12,0	8,80	Pe motor(kW)	0,75	1,1	1,1	1,1	1,5	1,5	2,2	2,2	2,2	2,2	2,2	3,0	3,0
					n (min <sup>-1</sup> )	680	750	820	890	950	1020	1080	1140	1190	1250	1300	1370	1420
6.180	1,72	13,0	10,34	Pe motor(kW)	1,1	1,1	1,5	1,5	1,5	2,2	2,2	2,2	2,2	3,0	3,0	3,0	3,0	
				n (min <sup>-1</sup> )	710	780	840	910	970	1030	1090	1150	1200	1270	1320	1370	1420	
6.650	1,85	14,0	11,98	Pe motor(kW)	1,1	1,5	1,5	1,5	2,2	2,2	2,2	2,2	3,0	3,0	3,0	3,0	---	
				n (min <sup>-1</sup> )	750	810	870	930	990	1050	1100	1160	1230	1280	1320	1380	---	
7.130	1,98	15,0	13,77	Pe motor(kW)	1,5	1,5	2,2	2,2	2,2	2,2	3,0	3,0	3,0	3,0	---	---		
				n (min <sup>-1</sup> )	780	840	900	960	1010	1070	1140	1190	1240	1290	1340	---		
7.600	2,11	16,0	15,64	Pe motor(kW)	2,2	2,2	2,2	2,2	2,2	3,0	3,0	3,0	---	---	---	---		
				n (min <sup>-1</sup> )	820	870	930	980	1040	1110	1160	1210	1260	---	---	---		

Selección Silenciosa   
  Selección Estandar   
  Selección Industrial

Tamaño	Caudal		Vel.Imp. C <sub>2</sub> (m/s)	Pres.Din(Pd) (mm.c.d.a.)	Potencia rpm	Presión Estática Pst (mm.c.d.a.)												
	V(m³/h)	V(m³/s)				10	15	20	25	30	35	40	45	50	55	60	65	70
<b>CEB-15/15 (15/15)</b>	6.190	1,72	9,0	4,95	Pe motor(kW)	0,75	0,75	1,1	1,1	1,5	1,5	2,2	2,2	2,2	2,2	3,0	3,0	3,0
					n (min <sup>-1</sup> )	480	550	620	690	750	810	870	920	980	1030	1080	1130	1180
	6.880	1,91	10,0	6,12	Pe motor(kW)	0,75	1,1	1,1	1,5	1,5	2,2	2,2	2,2	2,2	3,0	3,0	3,0	3,0
					n (min <sup>-1</sup> )	500	570	630	700	760	810	870	920	970	1020	1070	1120	1160
	7.570	2,10	11,0	7,41	Pe motor(kW)	1,1	1,1	1,5	1,5	2,2	2,2	2,2	3,0	3,0	3,0	3,0	4,0	4,0
					n (min <sup>-1</sup> )	520	590	650	710	760	820	870	920	970	1020	1060	1110	1150
	8.260	2,29	12,0	8,82	Pe motor(kW)	1,1	1,5	1,5	2,2	2,2	2,2	3,0	3,0	3,0	3,0	4,0	4,0	4,0
					n (min <sup>-1</sup> )	550	610	670	720	770	830	880	920	970	1020	1060	1110	1150
	8.940	2,48	13,0	10,33	Pe motor(kW)	1,5	1,5	2,2	2,2	2,2	3,0	3,0	3,0	3,0	4,0	4,0	4,0	4,0
					n (min <sup>-1</sup> )	570	630	680	740	790	840	880	930	980	1020	1060	1110	1150
9.630	2,68	14,0	11,99	Pe motor(kW)	2,2	2,2	2,2	3,0	3,0	3,0	4,0	4,0	4,0	4,0	4,0	4,0	---	
				n (min <sup>-1</sup> )	600	650	710	760	800	850	900	940	980	1030	1070	1110	---	
10.320	2,87	15,0	13,76	Pe motor(kW)	2,2	2,2	3,0	3,0	3,0	3,0	4,0	4,0	4,0	4,0	---	---	---	
				n (min <sup>-1</sup> )	630	680	730	780	820	870	910	950	990	1030	1070	---	---	
11.010	3,06	16,0	15,67	Pe motor(kW)	3,0	3,0	3,0	4,0	4,0	4,0	4,0	4,0	4,0	---	---	---		
				n (min <sup>-1</sup> )	660	710	750	800	840	880	930	970	1010	---	---	---		

Tamaño	Caudal		Vel.Imp. C <sub>2</sub> (m/s)	Pres.Din(Pd) (mm.c.d.a.)	Potencia rpm	Presión Estática Pst (mm.c.d.a.)												
	V(m³/h)	V(m³/s)				10	15	20	25	30	35	40	45	50	55	60	65	70
<b>CEB-18/40 (18/18)</b>	8.650	2,40	9,0	4,96	Pe motor(kW)	0,75	1,1	1,5	1,5	2,2	2,2	2,2	3,0	3,0	3,0	4,0	4,0	4,0
					n (min <sup>-1</sup> )	410	470	530	580	640	680	730	780	820	860	910	950	990
	9.610	2,67	10,0	6,12	Pe motor(kW)	1,1	1,1	1,5	2,2	2,2	2,2	3,0	3,0	3,0	4,0	4,0	4,0	4,0
					n (min <sup>-1</sup> )	430	490	540	590	640	690	730	780	820	860	900	940	980
	10.570	2,94	11,0	7,40	Pe motor(kW)	1,1	1,5	2,2	2,2	2,2	3,0	3,0	3,0	4,0	4,0	4,0	4,0	4,0
					n (min <sup>-1</sup> )	450	500	550	600	650	690	740	780	820	860	900	930	970
	11.530	3,20	12,0	8,81	Pe motor(kW)	1,5	2,2	2,2	2,2	3,0	3,0	3,0	4,0	4,0	4,0	5,5	5,5	
					n (min <sup>-1</sup> )	470	520	570	610	660	700	740	780	820	860	900	930	970
	12.490	3,47	13,0	10,34	Pe motor(kW)	2,2	2,2	2,2	3,0	3,0	3,0	4,0	4,0	4,0	5,5	5,5	5,5	
					n (min <sup>-1</sup> )	490	540	580	630	670	710	750	790	830	860	900	930	970
13.450	3,74	14,0	11,99	Pe motor(kW)	2,2	2,2	3,0	3,0	3,0	4,0	4,0	4,0	5,5	5,5	5,5	5,5		
				n (min <sup>-1</sup> )	510	560	600	640	680	720	760	800	830	870	900	940	970	
14.410	4,00	15,0	13,76	Pe motor(kW)	2,2	3,0	3,0	4,0	4,0	4,0	4,0	5,5	5,5	5,5	5,5	---		
				n (min <sup>-1</sup> )	540	580	620	660	700	740	770	810	840	880	910	---		
15.370	4,27	16,0	15,65	Pe motor(kW)	3,0	3,0	4,0	4,0	4,0	5,5	5,5	5,5	5,5	5,5	---			
				n (min <sup>-1</sup> )	560	600	640	680	720	750	790	820	860	890	---			

Tamaño	Caudal		Vel.Imp. C <sub>2</sub> (m/s)	Pres.Din(Pd) (mm.c.d.a.)	Potencia rpm	Presión Estática Pst (mm.c.d.a.)												
	V(m³/h)	V(m³/s)				10	15	20	25	30	35	40	45	50	55	60	65	70
<b>CEB-20/20 (20/20)</b>	11.780	3,27	9,0	4,95	Pe motor(kW)	2,2	2,2	2,2	2,2	2,2	3,0	3,0	3,0	4,0	4,0	4,0	5,5	
					n (min <sup>-1</sup> )	410	460	500	540	580	620	650	690	720	760	790	820	850
	13.090	3,64	10,0	6,12	Pe motor(kW)	2,2	2,2	2,2	2,2	3,0	3,0	3,0	4,0	4,0	4,0	5,5	5,5	
					n (min <sup>-1</sup> )	440	480	520	560	590	630	660	700	730	760	790	820	850
	14.400	4,00	11,0	7,40	Pe motor(kW)	2,2	2,2	3,0	3,0	3,0	4,0	4,0	4,0	5,5	5,5	5,5		
					n (min <sup>-1</sup> )	460	500	540	580	610	650	680	710	740	770	800	830	855
	15.710	4,36	12,0	8,81	Pe motor(kW)	3,0	3,0	3,0	4,0	4,0	4,0	4,0	5,5	5,5	5,5	5,5		
					n (min <sup>-1</sup> )	490	530	560	600	630	660	690	720	750	780	810	840	860
	17.020	4,73	13,0	10,34	Pe motor(kW)	3,0	3,0	4,0	4,0	4,0	4,0	4,0	5,5	5,5	5,5	7,5		
					n (min <sup>-1</sup> )	520	560	590	620	650	680	710	740	770	800	820	850	875
18.330	5,09	14,0	11,99	Pe motor(kW)	4,0	4,0	4,0	4,0	5,5	5,5	5,5	5,5	5,5	7,5	7,5			
				n (min <sup>-1</sup> )	550	580	620	650	680	700	730	760	790	810	840	860	890	
19.640	5,46	15,0	13,77	Pe motor(kW)	4,0	4,0	5,5	5,5	5,5	5,5	5,5	7,5	7,5	7,5	7,5			
				n (min <sup>-1</sup> )	580	610	640	670	700	730	750	780	810	830	860	880		
20.940	5,82	16,0	15,65	Pe motor(kW)	5,5	5,5	5,5	5,5	5,5	7,5	7,5	7,5	7,5	7,5	---			
				n (min <sup>-1</sup> )	610	640	670	700	720	750	780	800	830	850	---			

Selección Silenciosa   
  Selección Estandar   
  Selección Industrial

Tamaño	Caudal		Vel.Imp. C <sub>2</sub> (m/s)	Pres.Din(Pd) (mm.c.d.a.)	Potencia rpm	Presión Estática Pst (mm.c.d.a.)												
	V(m³/h)	V(m³/s)				10	15	20	25	30	35	40	45	50	55	60	65	70
<b>CEB-22/22 (22/22)</b>	14.750	4,10	9,0	4,95	Pe motor(kW)	2,2	2,2	2,2	3,0	3,0	4,0	4,0	4,0	5,5	5,5	5,5	5,5	7,5
					n (min <sup>-1</sup> )	380	420	460	490	530	560	600	630	660	690	720	750	780
	16.390	4,55	10,0	6,12	Pe motor(kW)	2,2	2,2	3,0	3,0	4,0	4,0	4,0	5,5	5,5	5,5	5,5	7,5	7,5
					n (min <sup>-1</sup> )	400	440	480	510	540	580	610	640	670	700	720	750	780
	18.030	5,01	11,0	7,40	Pe motor(kW)	3,0	3,0	3,0	4,0	4,0	5,5	5,5	5,5	5,5	7,5	7,5	7,5	7,5
					n (min <sup>-1</sup> )	430	460	500	530	560	590	620	650	680	700	730	760	780
	19.670	5,46	12,0	8,81	Pe motor(kW)	3,0	4,0	4,0	4,0	5,5	5,5	5,5	5,5	7,5	7,5	7,5	7,5	7,5
					n (min <sup>-1</sup> )	460	490	520	550	580	610	630	660	690	710	740	770	790
	21.310	5,92	13,0	10,34	Pe motor(kW)	4,0	4,0	5,5	5,5	5,5	5,5	7,5	7,5	7,5	7,5	7,5	9,2	9,2
					n (min <sup>-1</sup> )	490	510	540	570	600	620	650	680	700	730	750	780	800
	22.940	6,37	14,0	11,98	Pe motor(kW)	4,0	5,5	5,5	5,5	7,5	7,5	7,5	7,5	7,5	9,2	9,2	9,2	11,0
					n (min <sup>-1</sup> )	520	540	570	590	620	640	670	690	720	740	770	790	815
	24.580	6,83	15,0	13,76	Pe motor(kW)	5,5	5,5	7,5	7,5	7,5	9,2	9,2	9,2	9,2	11,0	11,0	11,0	11,0
					n (min <sup>-1</sup> )	550	570	590	620	640	670	690	710	740	760	780	800	830
	26.220	7,28	16,0	15,66	Pe motor(kW)	7,5	7,5	7,5	7,5	9,2	9,2	9,2	11,0	11,0	11,0	11,0	15,0	15,0
					n (min <sup>-1</sup> )	580	600	620	640	670	690	710	730	760	780	800	825	845

Tamaño	Caudal		Vel.Imp. C <sub>2</sub> (m/s)	Pres.Din(Pd) (mm.c.d.a.)	Potencia rpm	Presión Estática Pst (mm.c.d.a.)												
	V(m³/h)	V(m³/s)				10	15	20	25	30	35	40	45	50	55	60	65	70
<b>CEB-25/25 (25/25)</b>	19.680	5,47	9,0	4,95	Pe motor(kW)	2,2	2,2	3,0	3,0	4,0	4,0	5,5	5,5	7,5	7,5	7,5	7,5	11,0
					n (min <sup>-1</sup> )	300	340	380	420	450	480	520	550	580	605	635	665	695
	21.870	6,08	10,0	6,12	Pe motor(kW)	2,2	3,0	3,0	4,0	4,0	5,5	5,5	7,5	7,5	7,5	7,5	11,0	11,0
					n (min <sup>-1</sup> )	310	350	390	420	460	490	520	550	580	605	630	660	685
	24.050	6,68	11,0	7,40	Pe motor(kW)	3,0	4,0	4,0	4,0	5,5	5,5	7,5	7,5	7,5	11,0	11,0	11,0	11,0
					n (min <sup>-1</sup> )	330	370	400	430	460	490	520	550	580	605	630	655	680
	26.240	7,29	12,0	8,81	Pe motor(kW)	4,0	4,0	5,5	5,5	5,5	7,5	7,5	7,5	9,2	11,0	11,0	11,0	11,0
					n (min <sup>-1</sup> )	350	380	410	440	470	500	530	560	580	605	630	655	680
	28.430	7,90	13,0	10,34	Pe motor(kW)	4,0	5,5	5,5	5,5	7,5	7,5	7,5	9,2	9,2	11,0	11,0	11,0	15,0
					n (min <sup>-1</sup> )	370	400	430	460	480	510	540	560	590	610	635	660	680
	30.610	8,50	14,0	11,99	Pe motor(kW)	5,5	5,5	7,5	7,5	7,5	7,5	9,2	9,2	9,2	11,0	11,0	15,0	15,0
					n (min <sup>-1</sup> )	390	410	440	470	500	520	550	570	600	620	640	665	690
	32.800	9,11	15,0	13,76	Pe motor(kW)	5,5	7,5	7,5	7,5	9,2	9,2	9,2	11,0	11,0	15,0	15,0	15,0	15,0
					n (min <sup>-1</sup> )	410	430	460	490	510	540	560	580	605	630	650	670	695
	34.990	9,72	16,0	15,66	Pe motor(kW)	7,5	7,5	9,2	9,2	9,2	11,0	11,0	11,0	15,0	15,0	15,0	15,0	---
					n (min <sup>-1</sup> )	430	450	480	500	520	550	570	590	615	640	660	680	---

Tamaño	Caudal		Vel.Imp. C <sub>2</sub> (m/s)	Pres.Din(Pd) (mm.c.d.a.)	Potencia rpm	Presión Estática Pst (mm.c.d.a.)												
	V(m³/h)	V(m³/s)				10	15	20	25	30	35	40	45	50	55	60	65	70
<b>CEB-30/71 (30/28)</b>	26.900	7,47	9,0	4,95	Pe motor(kW)	2,2	3,0	4,0	4,0	5,5	5,5	4,5	7,5	7,5	7,5	9,2	9,2	11,0
					n (min <sup>-1</sup> )	240	270	310	340	360	390	420	440	470	490	520	540	560
	29.890	8,30	10,0	6,11	Pe motor(kW)	3,0	4,0	4,0	5,5	5,5	5,5	7,5	7,5	7,5	9,2	9,2	11,0	11,0
					n (min <sup>-1</sup> )	250	280	310	340	370	400	420	440	470	490	510	530	560
	32.880	9,13	11,0	7,40	Pe motor(kW)	4,0	4,0	5,5	5,5	7,5	7,5	7,5	9,2	9,2	9,2	11,0	11,0	15,0
					n (min <sup>-1</sup> )	270	300	320	350	370	400	420	450	470	490	510	530	555
	35.870	9,96	12,0	8,81	Pe motor(kW)	4,0	5,5	5,5	7,5	7,5	7,5	9,2	9,2	11,0	11,0	11,0	15,0	15,0
					n (min <sup>-1</sup> )	280	310	330	360	380	410	430	450	470	490	510	530	555
	38.860	10,79	13,0	10,34	Pe motor(kW)	5,5	5,5	7,5	7,5	7,5	9,2	9,2	11,0	11,0	15,0	15,0	15,0	15,0
					n (min <sup>-1</sup> )	300	320	340	370	390	410	430	460	480	500	520	540	560
	41.850	11,63	14,0	11,99	Pe motor(kW)	7,5	7,5	7,5	9,2	9,2	11,0	11,0	11,0	15,0	15,0	15,0	15,0	15,0
					n (min <sup>-1</sup> )	310	330	360	380	400	420	440	460	480	500	520	540	560
	44.840	12,46	15,0	13,76	Pe motor(kW)	7,5	9,2	9,2	9,2	11,0	11,0	15,0	15,0	15,0	15,0	15,0	---	---
					n (min <sup>-1</sup> )	330	350	370	390	410	430	450	470	490	510	530	---	---
	47.830	13,29	16,0	15,66	Pe motor(kW)	9,2	9,2	11,0	11,0	15,0	15,0	15,0	15,0	15,0	15,0	---	---	---
					n (min <sup>-1</sup> )	340	360	380	400	420	440	460	480	500	520	---	---	---

Selección Silenciosa   
  Selección Estandar   
  Selección Industrial

### Curvas de características

Las curvas de características han sido determinadas para una temperatura de aire de 20° C y una presión barométrica de 760 mm Hg, equivalente a una densidad de 1,2 Kg/m<sup>3</sup>.

Cualquier variación de estos valores implica la utilización de los coeficientes de corrección indicados en la tabla n°.1

### Ejemplo de aplicación:

Según las leyes de los ventiladores relativas a la variación de la densidad del aire, tenemos:

a) El caudal en volumen permanece invariable.  $V_1 = V_2$

b) La presión y la potencia absorbida a igualdad de caudal son proporcionales a la densidad.

$$\Delta pt_2 = \Delta pt_1 \frac{\gamma_2}{\gamma_1} \quad P_{A2} = P_{A1} \frac{\gamma_2}{\gamma_1}$$

Tabla n° 1

TEMPERATURA DEL AIRE °C	ELEVACION SOBRE EL NIVEL DEL MAR m.									
	Nivel del mar	300	450	600	750	900	1200	1500	1800	2100
	PRESION BAROMETRICA mm Hg									
	760	735	720	705	695	680	655	630	610	585
-40	1,234	1,191	1,170	1,150	1,128	1,105	1,066	1,028	0,987	0,956
-18	1,152	1,110	1,092	1,072	1,052	1,033	0,950	0,957	0,922	0,894
0	1,082	1,043	1,024	1,005	0,990	0,970	0,934	0,900	0,865	0,838
20	1,000	0,964	0,947	0,930	0,913	0,896	0,864	0,832	0,799	0,774
38	0,946	0,912	0,895	0,878	0,863	0,847	0,816	0,785	0,755	0,732
66	0,869	0,838	0,824	0,807	0,793	0,779	0,750	0,722	0,695	0,672
93	0,803	0,775	0,760	0,747	0,733	0,720	0,693	0,667	0,642	0,622
121	0,747	0,720	0,707	0,695	0,682	0,670	0,645	0,622	0,592	0,578
149	0,679	0,672	0,660	0,647	0,626	0,625	0,602	0,579	0,577	0,540
177	0,654	0,630	0,620	0,608	0,597	0,586	0,564	0,543	0,522	0,507
205	0,616	0,594	0,583	0,572	0,562	0,552	0,532	0,512	0,482	0,477

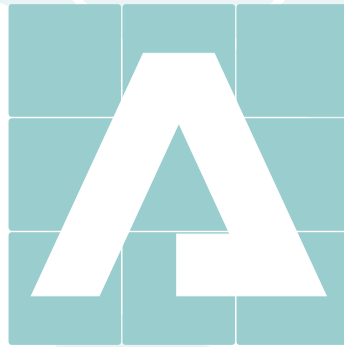

## difusión - acústica - cortafuego ventilación



**Airsum S.L.**

NIF: ES B28 318236

Alcotanes, 17 - P.I. El Cascajal  
E-28320 Pinto (Madrid)



(+34) 91 692 72 40



airsum@airsum.es



www.airsum.es